

GENERAL INSTRUCTIONS

CONSOLIDATED DUTCHWEST STOVES & FIREPLACE INSERTS



— Dutchwest Pre 1990 —

SAFETY NOTICE: *IF THIS STOVE IS NOT PROPERLY INSTALLED A HOUSE FIRE MAY RESULT. FOR YOUR SAFETY, FOLLOW THE INSTALLATION DIRECTIONS. CONTACT LOCAL BUILDING OR FIRE OFFICIALS ABOUT RESTRICTIONS AND INSTALLATION REQUIREMENTS IN YOUR AREA. *Be sure to read the "Do's and Don'ts" of safe stove operation at the end of this booklet before operating your stove.*



Our Thanks

We sincerely thank you for choosing a Consolidated Dutchwest stove. Your new stove is one of the finest and technologically most advanced stoves ever developed. By following the instructions in this booklet, you can ensure that your stove will provide you with years of safe, dependable, and economical heating. Please operate it with the care it deserves. Should you need advice on the installation, operation, or maintenance of your Consolidated Dutchwest stove, please call Team Fireside at 1-800-22-STOVE (1-800-227-8683), and discuss your questions with one of our experienced technicians.

SAFETY NOTICE: IF THIS STOVE IS NOT PROPERLY INSTALLED A HOUSE FIRE MAY RESULT. FOR YOUR SAFETY, FOLLOW THE INSTALLATION DIRECTIONS. CONTACT LOCAL BUILDING OR FIRE OFFICIALS ABOUT RESTRICTIONS AND INSTALLATION REQUIREMENTS IN YOUR AREA. *Be sure to read the "Do's and Don'ts" of safe stove operation at the end of this booklet before operating your stove.

COMPREHENSIVE INSTALLATION & OPERATING INSTRUCTIONS

Pertaining to All Current Consolidated Dutchwest Stoves & Fireplace Inserts

Covering the Following Freestanding Models:

FA288CCL, FA264CCL, FA224CCL, FA224ACL

FA211CL, FA209CL, FA207CL, FA267CL

FA264CCL-R, FA455 and Inserts:

7A, 7B, 8A, 8B, 8C, 8A-R, 8B-R, 8C-R, 9B, 9C, 11B

STOVE	HEAT OUTPUT Range (Btu/hr)
FA207CL	6,200 to 28,000
FA209CL	9,000 to 25,600
FA211CL	6,800 to 27,800
FA224ACL	7,200 to 30,000
FA224CCL	7,000 to 30,600
FA264CCL	6,600 to 26,700
FA267CL	8,400 to 40,000
FA288CCL	8,400 to 38,700
FA455	8,700 to 60,300

This manual describes the installation and operation of the Consolidated Dutchwest catalytic equipped wood heaters and fireplace inserts listed above. These units meet the U.S. Environmental Protection Agency emissions limits for wood heaters sold between July 1, 1988 and June 30, 1992. Under specific test conditions these heaters have been shown to deliver heat in the ranges shown in table at the left. Thank you for your purchase of a Consolidated Dutchwest stove or fireplace insert. The information contained in these instructions is intended to:

- (1) make certain you properly install your stove,
- (2) make all features and stove functions clear and comprehensible,
- (3) help you to maximize your stove's performance and efficiency.

Read these instructions carefully before starting. Your stove must be installed in accordance with all local and applicable national building codes. The information that follows assumes you will correctly follow all instructions. The safe installation and operation of your stove is dependent on your following all rules that apply. **YOUR WOOD HEATER CONTAINS A**

CATALYTIC COMBUSTOR, WHICH NEEDS PERIODIC INSPECTION AND REPLACEMENT FOR PROPER OPERATION. IT IS AGAINST THE LAW TO OPERATE THIS WOOD HEATER IN A MANNER INCONSISTENT WITH THE OPERATING INSTRUCTIONS IN THIS MANUAL, OR IF THE CATALYTIC ELEMENT IS DEACTIVATED OR REMOVED. Note that UNIT MUST BE PROPERLY ASSEMBLED AND INSTALLED OR SAFETY LISTING WILL BE VOID. BE SURE TO READ THE "DO'S AND DON'TS OF OPERATING YOUR STOVE" IN THE BACK OF THIS BOOKLET, AS IT CONTAINS MANY ESSENTIAL GUIDELINES TO SAFE STOVE INSTALLATION AND OPERATION. Save these instructions for future reference.

CAUTION: Your Federal Airtight stove is one of the finest, most versatile, efficient, and easy to use heaters available in the world today. It has also been designed to be very safe to operate. NEVERTHELESS, THIS AND ALL STOVES AND HEATING DEVICES HAVE THE POTENTIAL TO BE DANGEROUS IF NOT OPERATED PROPERLY. THEREFORE, IT IS OF THE UTMOST IMPORTANCE THAT YOU FOLLOW ALL INSTRUCTIONS CAREFULLY. ALL ASSEMBLY, OPERATING AND MAINTENANCE, INSTALLATION, AND FIRE STARTING INSTRUCTIONS MUST BE FOLLOWED TO ENSURE THE SAFEST STOVE OPERATION POSSIBLE.

The detail in these instructions may seem excessive. Don't let it intimidate you. We have made our instructions detailed because we want you to operate your stove safely. Safe stove operation is extremely important. Follow these installation and stove operation instructions carefully, and your Federal Airtight will provide you with many years of dependable, economical, and comfortable heating.

CAUTION: Unless you have the knowledge of an expert yourself, you should consult a professional chimney installer to advise you or do your installation. While the assembly of your stove is very easy, there are many safety factors involved in its installation and maintenance. We have tried to set out guides to installation and maintenance in as clear a manner as possible, but this is not a substitute for expert knowledge. Remember, a wood and coal stove is not a simple device like a small space heater. Like a furnace, it is a serious heat producer, and as such, it has the potential to be dangerous if not properly installed and operated. Few people with little knowledge of the field would attempt to install an oil or gas furnace or electric heating system in their home without professional assistance, even if given a complete set of instructions on how to do so. You should treat any wood and coal stove with the same respect. The installation instructions should be used as guides for the knowledgeable person, rather than as a course for the beginner. The beginner should always seek professional assistance. *Your safety and well being depend on proper installation and maintenance and your safety is more important than anything else.*

ASSEMBLY INSTRUCTIONS

Included with these general instructions is a separate assembly instruction that applies to your stove or insert. If you are unable to locate these instructions or if they have been misplaced, contact the Consolidated Dutchwest Service Department for a replacement copy.

Your stove must be installed in full accordance with the assembly instructions or the safety listing will be void.

GENERAL INSTRUCTIONS TABLE OF CONTENTS:

Assembly Instructions.....	page 2
Installation Instructions.....	page 2
Freestanding Installations.....	page 2
Proper Pipe Configuration.....	page 5
Fireplace Adapter Installations.....	page 9
Fireplace Insert Installations.....	page 10
Stove Operation Instructions.....	page 12
Combustion Air and Draft Control.....	page 12
Coal Burning.....	page 15
Wood Burning.....	page 16
Maximizing Efficiency and Controlling Burn Times.....	page 17
Troubleshooting Guide.....	page 22
The Do's and Don'ts of running a stove.....	page 24

INSTALLATION INSTRUCTIONS

Most safety problems associated with stoves are caused by either improper installations or creosote build-up in the pipe or chimney. Observe all clearances called for in these instructions. You must not make wishful assumptions as to your proposed installation. Failure to follow these instructions may result in damage to your stove, or possibly result in a serious chimney or house fire. Take due care and you will enjoy many years of safe, effective operation.

We have designed each Consolidated Dutchwest stove to be installed in a variety of ways. This versatility we've built in means you have maximum flexibility in determining how to install your stove now and in the future. All models may be installed in the freestanding mode, or in a corner, and as a fireplace adapter - that is - set in front of a fireplace and vented into an existing chimney. All convection models may also be installed as fireplace inserts.

All of our stoves and inserts can be installed in a zero-clearance fireplace provided (1) there is a direct stovepipe connection between the stove's flue collar and the start of the fireplace's chimney system, and (2) the sealing plates surrounding the insert do not block off any of the fireplace's circulating air vents. Some communities require testing with specific brands of zero-clearance fireplaces, check with local officials for regulations in your area.

INSTRUCTIONS FOR FREESTANDING INSTALLATIONS

For each model we have had Arnold Greene Testing Laboratories of Natick, Massachusetts undertake testing to the U/L Standard to determine the minimum permissible distance that each stove may be located both to combustible back and side walls, as well as protected back and side walls. Through testing we have also established clearances for optional "clearance reduction kits" which mount on the stove back. In this way we have tried to provide a wide variety of safe alternatives for installation. When locating your stove, consider safety, convenience, traffic flow, and the fact that the stove will need a chimney and stovepipe. Your stove should be located away from doors and hallways and in an open area to allow for necessary clearances. Minimum clearances for conventional freestanding installations and corner installations are shown on page 4. Combustibles, protected combustibles, and non-combustibles are defined in the next section under "Establishing Combustibles" see page 3.

ESTABLISHING COMBUSTIBLES

Because there are several sets of clearances whose use depends on the materials in proximity to your intended installation, we have included here a brief section intended to answer the most frequently asked questions about combustibles and non-combustibles. If in doubt, contact your local building inspector for an expert opinion. **Note:** all clearances are measured from stove body to combustible surface.

What's the difference between a combustible, a protected combustible, and a non-combustible?

Combustible: This is a surface that will burn if exposed to the high heat of a stove. Typically such walls are wood or sheetrock over wood studs. Brick over combustible materials such as wood studs also constitutes a combustible wall. Z-brick, wallpaper and plastic clearly fall into this category.

Protected Combustible: This is a combustible surface which has been protected by the addition of a protective shield. Such protective shields are available through Consolidated Dutchwest. A protected combustible may also be created by building a brick wall in front of a combustible wall and allowing at least 1" air space. The air space is crucial, since it keeps the heat conducted through the brick from passing to the adjoining combustible surface. It is also crucial that there be openings at the top and bottom of the shield or top and two sides, so that air can circulate through the shielded space. Otherwise, trapped air in this space can become extremely hot and will transfer heat to the adjacent combustible walls. (See figure 2)

Non-Combustible: This is a non-flammable wall such as cinder block with no combustible material behind it or within the wall. Basement walls frequently meet this standard.

What about regular brick walls? An often asked question is whether a brick wall is a non-combustible or perhaps at least a protected combustible. The answer is usually no. Brick interior walls in houses are usually classified as combustible, unless it is absolutely 100% certain that there's no combustible material behind the brick. While it's true brick won't burn, it conducts heat. Brick walls must be treated as combustible unless the builder has specifically built the walls in question to be noncombustible, or if the homeowner can be completely certain the brick isn't covering or in contact with combustible materials.

How can I safely reduce clearances? If the area where you intend to install your stove is combustible, the best and easiest answer is to add a clearance reduction kit. Such kits are inexpensive and typically permit a reduction of 50% or more of the back wall clearances. If the clearance is still too great, you have the option of protecting the back wall, after which you may further reduce the clearance another 50%. As an example, the normal clearance to a combustible back wall for the FA264CCL is 30½". If a clearance reduction kit is used the clearance then becomes 15". If the back wall is a protected combustible rather than a combustible wall, the clearance without a clearance reduction kit is 18". If you both protect your combustible wall and use a clearance reduction kit, the clearance may be reduced to 7½". Refer to the chart on page 4 for clearances for your stove and read the following sections on the various ways to reduce clearances.

FLOOR PROTECTORS — MINIMUM DIMENSIONS

Each of our stoves requires, for conventional and corner free standing installations, floor protection under it, unless the floor is completely made of cement, concrete, or another form of solid masonry. Such floor protection should be constructed of non-combustible millboard (approved for this application by a listing or certifying organization) or the equivalent. The protector must have a thermal conductivity of $K = 0.84 \text{ BTU IN/FT}^2 \text{ HR } ^\circ\text{F}$ or less. A few of the names under which material meeting this criteria is sold in board form are as follows: Ceraform Board Type 106-R or Type 126 by Johns-Manville, Fiberfrax Duraboard LD by Carborundum, and MICOR CV230 by U.S. Gypsum. A layer of sheet steel or tile may be used to protect the insulating board. A double thickness of protection should be used for the following models: FA207CL, FA209CL, FA211CL, FA224ACL, & FA267CL. **You should seek the approval of your local building inspector, or authority having jurisdiction, for any floor protection you propose to use.** You may also wish to check with the inspector to see if a layer of brick or stone or other material is an acceptable equivalent under local ordinances. They may allow, as an alternative, a layer of brick or stone over a thin sheet of steel, bordered and fully secured by quarter round wooden molding. Spaces between bricks are filled in with sand. The clearances listed below indicate the number of inches floor protection should extend from each side of your stove and the minimum total floor size required for each model. (Note: Stoves with side loading doors require more floor protection on one side of the stove than on the other. You may feel that having the same amount of floor protection on each side of the stove looks better, in which case you can add to the required width. **Do not reduce any side protection extensions under any circumstances.**

Table 1 **FREESTANDING MINIMUM HEARTH PROTECTOR DIMENSIONS**

Stove	A	B	C	D	width	depth
FA207CL	16"	8"	8"	8"	38"	40"
FA209CL	16"	12"	12"	8"	38"	45"
FA211CL	16"	16"	16"	8"	52"	45"
FA224ACL	16"	16"	8"	8"	47"	42"
FA224CCL	16"	16"	8"	8"	47"	42"
FA264CCL	16"	16"	8"	8"	50"	44"
FA288CCL	16"	16"	8"	8"	53"	44"
FA267CL	16"	16"	8"	8"	50"	47"
All Inserts (not including right-side loading)	16"	16"	8"	N.A.		
8A-R, 8B-R, 8C-R	16"	8"	16"	N.A.		
FA264CCL-R	16"	8"	16"	8"	50"	44"
FA455	16"	16"	8"	8"	50"	42"

A: Stove Front
B: Stove Left Side
C: Stove Right Side
D: Stove Back

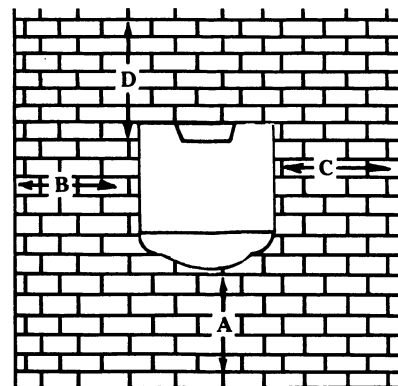

Figure 1

PROTECTING YOUR WALLS

Stoves can be safely placed closer to protected walls than to combustible ones. If you don't have enough space to meet the necessary wall clearances or should you wish to minimize the area utilized by your stove installation, you have three options. They are (1) install a clearance reduction kit, (2) install back wall protection or (3) install both a clearance reduction kit and wall protection. Each option and its corresponding clearances is explained on page 4. Clearance reduction kits are the easiest and least expensive approach. If you intend to meet the normal (unprotected) clearances, or install your stove in front of a noncombustible wall or fireplace, you need not read the sections on clearance reduction kits and wall protectors.

Table 2

FREESTANDING MINIMUM CLEARANCES TO WALLS

Stove Model #	Distance										SW: Side Wall SW/P: Protected Side Wall* BW: Back Wall BW/P: Protected Back Wall* BW/RC: Back Wall Clearance with Reduction Kit BW/P&R: Back Wall Clearance with Reduction Kit & Protected Back Wall* Back Vent/Top Vent ⁶ C: Side Walls for Corner Installation C/P: Protected Side Walls for Corner Installation* C/W: Clearances to unshielded walls w/ clearance reduction kit & wings C/P/W: Clearance w/ both wall protectors & clearance reduction kits w/ wings
	SW	SW/P	BW	BW/P	BW/RCBW ⁶ /P&R	C	C/P	C/W	C/P/W		
FA207CL	36"	18"	38"	18"	15"	7½"8"	30"	18"	21"	10½"	
FA209CL	36"	18"	38"	18"	15"	7½"8"	30"	18"	21"	10½"	
FA211CL	34"	18"	39"	18"	20"	10"10"	30"	18"	21"	10½"	
FA224ACL	24"	18"	36"	18"	15"	7½"10"	34"	18"	21"	10½"	
FA224CCL	36"	18"	30½"	18"	15"	7½"10"	36"	18"	21"	10½"	
FA264CCL/R	36"	18"	30½"	18"	15"	7½"10"	36"	18"	21"	10½"	
FA267CL	32"	18"	39"	22"	20"	10"10"	32"	18"	21"	10½"	
FA288CCL	28"	18"	30"	18"	15"	7½"12"	28"	18"	21"	10½"	
FA455	24"	18"	42"	21"	20"	10"14"	42"	21"	16"	10½"	

* See the section on "Corner Installations" for determining the appropriate size of back or side wall protection. Wall protectors should be made from an approved non-combustible wall board on 1" spacers. (See "Wall Protectors" below)

WALL PROTECTORS

There are many fine wall protectors commercially available today which have been designed and approved for use with woodstoves. Such wall protectors will allow for reduced clearances to the back wall. You may also construct wall protection by installing ¼" approved non-combustible wall board or its equivalent spaced 1" from the combustible back wall. See Figure 3. Check with local building officials as to what materials constitute a suitable equivalent. Alternatively, a brick wall with a 1" airspace between it and a combustible back wall (figure 2) is frequently acceptable to building code officials. This wall must be at least one inch from the ceiling and 50% of the bottom must be open to allow air passage through the air space. Table 3 contains the standard back wall clearances, the reduced clearances attainable with the use of wall protection, and the dimensions (width and height) for the back wall area to be protected.

Table 3

Stove Model	Regular Clearance	Reduced Clearance	Wall Protection Width	Height
FA207CL	38"	18"	81"	61"
FA209CL	38"	18"	81"	61"
FA211CL	39"	18"	84"	65"
FA224ACL	36"	18"	86"	61"
FA224CCL	30½"	18"	72"	54"
FA264CCL/R	30½"	18"	76"	54"
FA288CCL	30"	18"	76"	56"
FA267CL	39"	22"	92"	63"
FA455	42"	21"	98"	66"

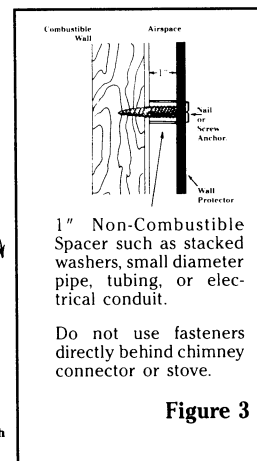
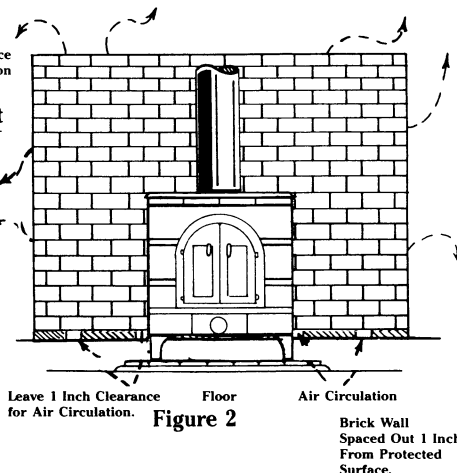

CLEARANCE REDUCTION KITS

Consolidated Dutchwest offers Clearance Reduction Kits which, when installed on the back of a stove, significantly reduce the clearance to combustible back walls. The regular clearance and the reduced clearance possible with the installation of these kits are shown below. Such kits are usually the least expensive method of reducing clearances.

Table 4

Stove	Kit #	Regular Clearance	Reduced Clearance
FA207CL	HS207	38"	15"
FA209CL	HS207	38"	15"
FA211CL	HS211	39"	20"
FA224ACL	HS224A	36"	15"
FA224CCL	HS224C	30½"	15"
FA264CCL/R	HS264	30½"	15"
FA288CCL	HS288	30"	15"
FA267CL	HS267	39"	20"
FA455	HS455	42"	20"

These kits attach to the stove back and can be installed in 15 minutes.

When using a clearance reduction kit and venting straight up (as opposed to venting out the back) black pipe protection is required. You may (1) use black double wall pipe or (2) use pipe guards. All models require pipe protection starting where the pipe is attached to the stove's flue collar.

Table 5 PIPE SHIELDS

Item#	Description
PG1-6	1'-6" diameter pipe guard
PG2-6	2'-6" diameter pipe guard
PG1-8	1'-8" diameter pipe guard
PG2-8	2'-8" diameter pipe guard

COMBINING A CLEARANCE REDUCTION KIT WITH WALL PROTECTION

When a Clearance Reduction Kit is combined with wall protection, both the back wall clearance and the size of the wall protection are reduced. Consolidated Dutchwest offers a line of wall protectors designed for use with the Clearance Reduction Kits. Shown in Table 6 for each stove are the Clearance Reduction Kits and the reduced wall protectors dimensions which apply when a clearance reduction kit is installed. **Do not under any circumstances use the reduced wall protector dimensions without the Clearance Reduction Kit.**

Stove	Regular Clearance	CRK**	Reduced Clearance** w/CRK* & WP†	Wall Protection Width	Depth
FA207CL	38"	HS207	7½" 8"	38"	40"
FA209CL	38"	HS207	7½" 8"	38"	40"
FA211CL	39"	HS211	10" 10"	52"	47"
FA224ACL	36"	HS224A	7½" 10"	47"	42"
FA224CCL	30½"	HS224C	7½" 10"	47"	42"
FA264CCL/R	30½"	HS264	7½" 10"	53"	44"
FA228CCL	30"	HS288	7½" 12"	53"	44"
FA267CL	39"	HS267	10" 10"	54"	47"
FA455	42"	HS455	10" 14"	54"	48"

* Clearance Reduction Kit † Wall Protector **Back vented/Top vented

Note: In the main catalogue Clearance Reduction Kits and Wall Protectors are fully described. Floor and wall protectors are available in a variety of finishes.

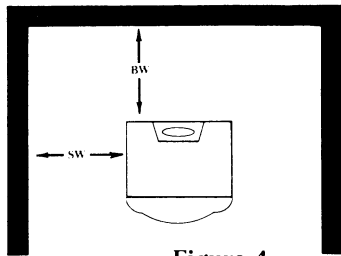

Figure 4

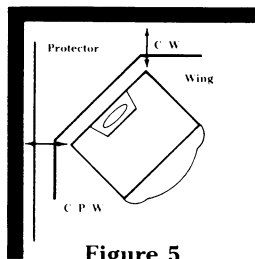

Figure 5

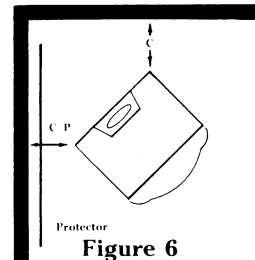

Figure 6

CORNER INSTALLATION

It's not unusual to want to position a stove in a corner. Frequently such positioning can minimize the floor area allocated for a stove. Clearances are indicated as C (to combustibles) and C/P (to protected combustibles) in figure 6. For corner installations, as for free standing installations, walls must be protected to a height of about 60" if the reduced clearances allowed for protected combustibles are used, (see Installation Planner, Table 6, for specific height and width requirements).

To determine the exact size of wall protector needed, site your stove where you intend to locate it. Using cardboard or other material as a mock shield, determine when this shield is spaced out one inch or more (depending on how you intend to attach it) from the wall, what height and width it must be so that no unshielded portion of the wall is closer to any portion of the stove than unprotected clearances allow. See Figure 7. "A" refers to measurements which must meet normal unprotected clearances from your stove, while measurements to the actual protector need only meet the protected combustible clearances. An intervening window, even if fully non-combustible, probably will not be workable because the heat from the stove can crack the glass. Note that access to the side loading door, if your stove has one, ought not to be restricted by your positioning of the stove in a corner installation. Side loading is an important and attractive feature which should be utilized.

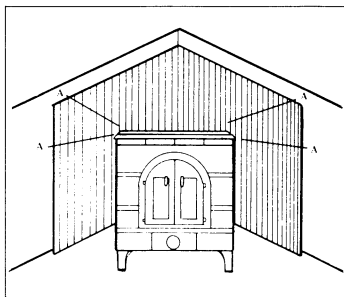

Figure 7

Clearances in corner installations can be minimized by using a clearance reduction kit with a 'wing' set attached (see Figure 5). This combination of shields will cut corner clearances to 21" for an unprotected wall or 10½" for a protected wall. Wing sets are panels that bolt to both sides of the clearance reduction kit and shield the walls in the corners of the room. For stove models FA207CL and FA209CL, use wing set HS207W. For FA211CL, use HS211W. For FA244ACL, use HS224AW. For FA224CCL, use HS224CW. For FA264CCL and FA264CCL-R, use HS264W. For FA267CL, use HS267W. For FA288CCL, use HS288W. For FA455, use HS455W.

CONFIGURING YOUR PIPE PROPERLY

In planning your installation there are several rules about pipe which must be observed. Black pipe is subject to its own set of clearances or those set by the pipe manufacturer's instructions (generally 18" for single wall and 6" for double wall). When venting straight up it's usually easy to maintain the required clearances but if you vent out the back or vent up and then over you need to remember that clearances to walls, ceiling and floor must be observed. When a Clearance Reduction Kit is used it is necessary to either shield the black pipe with pipe shields or substitute double wall black pipe.

Remember: Your pipe should always be rising. Over a brief distance (2 feet or less) your pipe may be flat, but in the main, it should be rising to assure proper draft. It must never dip.

In this literature we differentiate between pipe and chimney. Pipe is usually single wall and black, and connects the stove to the chimney. Chimney is defined as a fully insulated stack which, on a free standing installation, usually begins at the ceiling and continues up through as many floors as you have, through the attic and out through the roof a minimum of three (3) feet. Black pipe is used only to make the initial connection from the stove to the chimney.

STOVEPIPE ASSEMBLY

The stovepipe must be the same or greater nominal diameter as the flue collar provided with the stove model, and no less than 24 gauge cold rolled black steel. Do not use aluminum pipe. It cannot properly withstand the extreme temperatures of a wood fire. Do not use stovepipe as a chimney. It is important for stovepipe to be assembled so that any condensation which may occur within it remain in the pipe and not drip from the joints. This is done by inserting the first pipe section into the flue collar or the oval-to-round adapter. Each successive link should be inserted the same way. In other words, each pipe should go into the piece below it. (See Figure 8) The smoke will follow the path of least resistance and travel up the center of the pipe. All joints should be secured with three sheet metal screws. Otherwise, in the event of a creosote fire, the stovepipe may vibrate apart.

If you are attaching stovepipe to a flue collar or an oval-to-round adapter which has a flue damper in it, you will need to cut slots in the pipe so that it will slide past the damper axle for a proper fit. (See Figure 9)

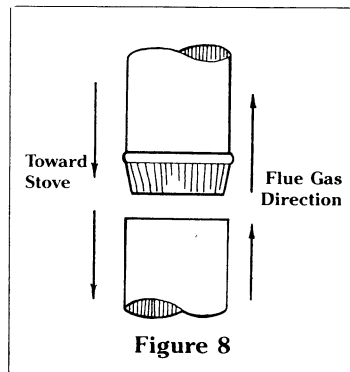

Figure 8

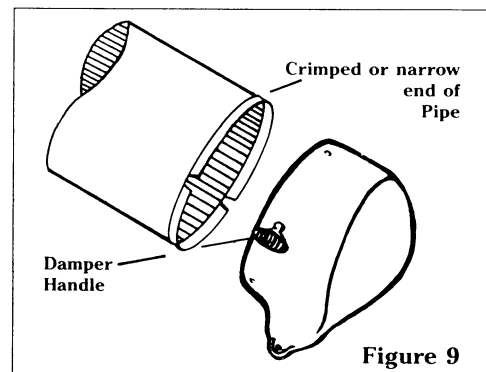

Figure 9

STOVEPIPE ASSEMBLY (Cont.)

There are four ways to vent a free standing stove (clockwise from upper left):

- (1) off the top and through a side wall; (see Figure 10)
- (2) out the back and through the wall; (see Figure 11)
- (3) off the top and through the roof; (see Figure 12)
- (4) out the back and through the roof; (see Figure 13)

Some of the advantages of each are as follows:

Venting from the top. Having no piping behind the stove, it will be possible to place the stove closer to the a back wall, taking less space (it is, however, still necessary to observe all clearances). You will also get a bit more heat from the stove, since the pipe radiates heat too.

Venting through an outside wall. This will make the pipe less visible if you prefer not to see it, and a bit easier to install than going through the roof.

Venting through the roof. By venting through the roof (and therefore running your chimney pipe inside the house) you will increase the stove's heating output as the pipe will be radiating additional heat. It will also reduce the likelihood of creosote formation and draft problems, and therefore, we recommend this type of installation.

Venting from the back. If you don't particularly like a stovepipe's appearance, it will be less noticeable in this type of installation.

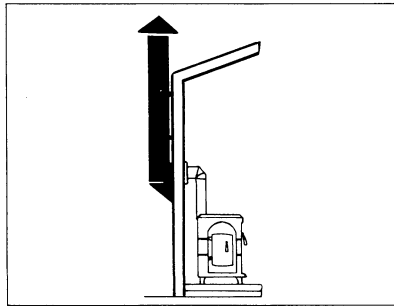

Figure 10

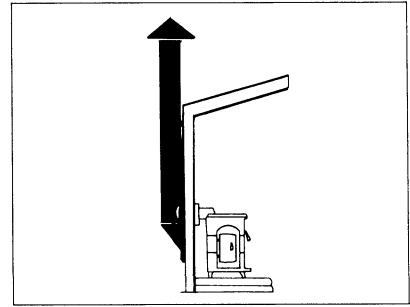

Figure 11

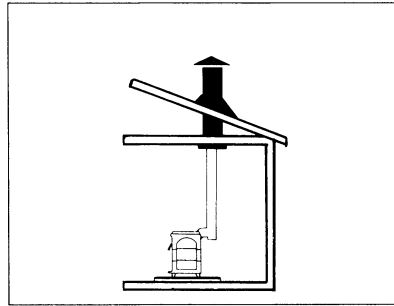

Figure 13

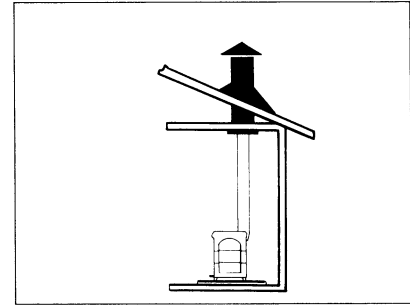

Figure 12

CONNECTION TO A METAL PREFABRICATED CHIMNEY

When a metal prefabricated chimney is used, the manufacturer's installation instructions must be followed precisely. You must also purchase (from the same manufacturer) and install the ceiling support package or wall pass through and "T" section package, firestops (when needed), insulation shield, roof flashing, chimney cap, etc. Be sure to check local codes before proceeding with your installation. These items both individually and in kit form are available from Consolidated Dutchwest. Maintain the proper clearance to the structure as recommended by the manufacturer. This clearance is usually a minimum of 2 inches, although it may vary by manufacturer or for certain components.

There are basically two methods of metal chimney installation. One method is to install the chimney inside the residence through the ceiling and the roof (Figures 14 and 15). The other method is to install an exterior chimney that runs up the outside of the residence (Figures 16 and 17). The components illustrated may not look exactly like the system you purchase, but they demonstrate the basic components you will need for a proper and safe installation.

The chimney must be the required height above the roof or other obstruction for safety and for proper draft operation. The requirement is that the chimney must be at least 3 feet higher than the highest point where it passes through the roof and at least 2 feet higher than the highest part of the roof or structure that is within 10 feet of the chimney, measured horizontally (Figure 21).

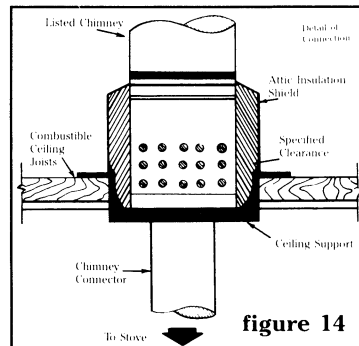

figure 14

Install an attic insulation shield to maintain the specified clearance to insulation. Insulation in this air space will cause a heat buildup which may ignite the ceiling joist.

This method of installation requires at minimum a ceiling support package, an insulation shield, and roof flashing.

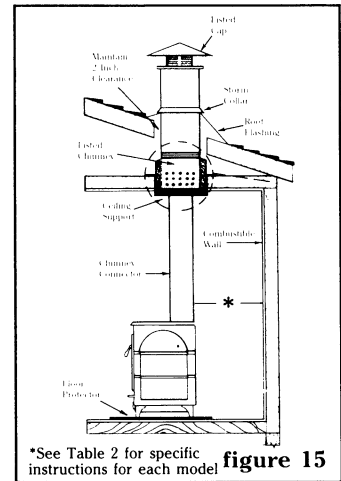

figure 15

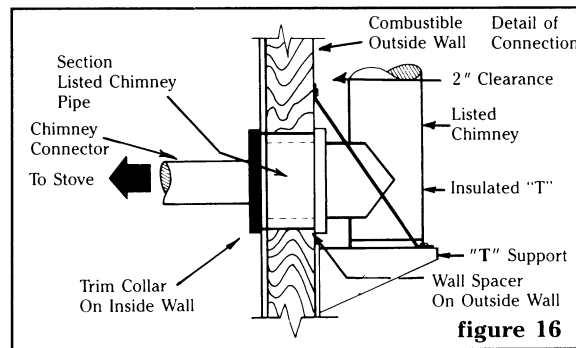

figure 16

This method of installation requires at minimum a wall pass through device, a "T" support package and insulated "T" section.

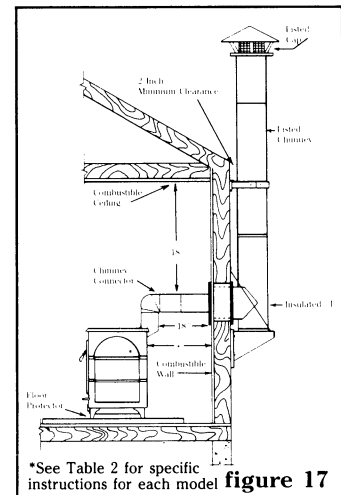

figure 17

REMEMBER: Follow the manufacturer's installation instructions and maintain the manufacturer's specified clearance distances.

CONNECTION TO A MASONRY CHIMNEY

Your stove may be connected to a lined masonry chimney or a listed high temperature prefabricated residential type building heating appliance chimney. **Do not** connect it to a chimney serving another appliance. To do so will affect the safe operation of both appliances.

Chimney

Should the stove be connected to a masonry chimney, the chimney should be examined for cracks, loose mortar, other signs of deterioration, and blockage. The stove should not be installed until it is determined that the chimney is safe for use. Since an oversized flue contributes to the accumulation of creosote, the size of the flue should be checked to determine that it is not too large for the stove. As a rule, chimney volumes up to twice or 2½ times that of the flue outlet will perform satisfactorily. For all Federal Airtights, except the Extra-Large Convection Heater (model FA288CCL) and Sequoia (model FA455), the stove can vent into an 8" by 8" masonry flue or an 8" round chimney flue. For the FA288CCL and FA455, the stove can vent into an 8" by 12" masonry or 10" round chimney flue. If your masonry chimney is larger than twice to 2½ times the flue outlet, we recommend installing a metal or other type of liner which reduces the chimney volume, thereby improving stove performance. The chimney should also be checked to ensure it meets the minimum standards of the National Fire Protection Association (NFPA) Standard 211. Copies of this standard can be obtained thru your local building inspector or state government. Following is a list of the more critical minimum requirements for a properly constructed chimney

- The masonry wall of the chimney, if brick or modular block, must be a minimum of 4 inches nominal thickness. A mountain or rubble stone wall must be at least 12 inches thick.
- The chimney must have a fire clay flue liner (or equivalent) with a minimum thickness of 5/8 of an inch and must be installed with refractory mortar. There must be at least a ½-inch air space between the flue liner and the chimney wall (Figure 18). An equivalent liner must be a listed chimney liner system or other approved material.
- A chimney inside the house must have at least 2 inches of clearance to the combustible structure. A chimney outside the house must have at least one inch clearance to the combustible structure. Fire stops must be installed in the spaces where the chimney passes through the floors and/or ceiling (Figure 20).

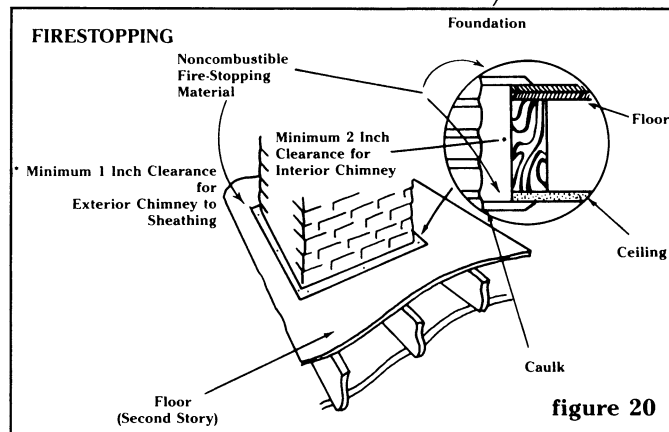
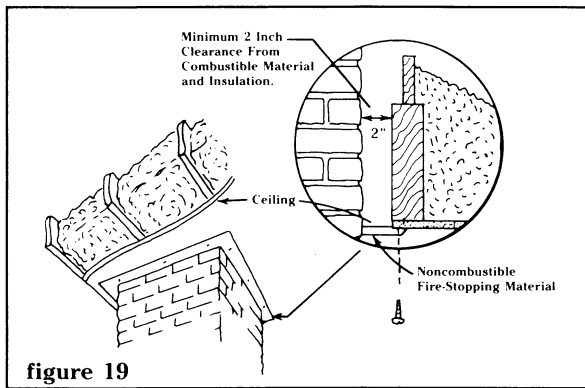
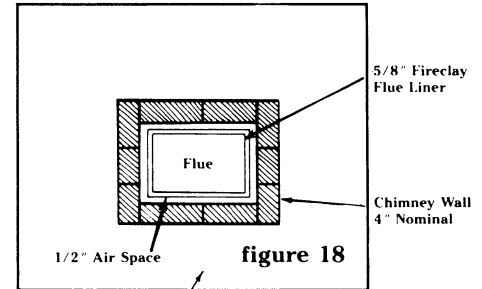

Remember that insulation must not contact the chimney. There must be air space around the chimney. Insulation must be 2 inches or more from the chimney (Figure 19).

A chimney must be the required height above the roof or other obstruction for safety and for proper draft operation. The requirement is that the chimney must be at least three feet higher than the highest point where it passes through the roof and at least 2 feet higher than the highest part of the roof or structure that is within 10 feet of the chimney, measured horizontally (Figure 21).

Thimble

A thimble must be used when the connection from the stove is made through a combustible wall to a masonry chimney. There are several methods to use for connection through a combustible wall, two of which are illustrated in this manual. Local building authorities should be consulted or NFPA 211, which covers additional methods of chimney connection. You should also contact the chimney connector manufacturer for any specific requirements regarding wall or ceiling pass-throughs.

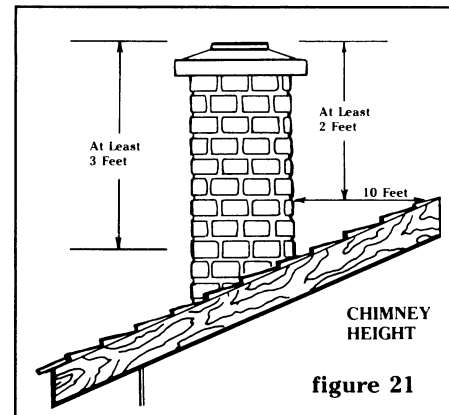

Also, listed prefabricated metal thimbles can be bought for use with wood stoves. The manufacturer's installation instructions must be strictly followed to insure the safety of the system. Be sure to maintain the designated clearance to combustible materials.

a. Brick chimney thimble assembly

Construction of the brick thimble assembly requires 12 inches of brick around a fire clay liner. It will be necessary to cut wall studs and install a header and sill frame to maintain proper dimensions and to hold the weight of the brick (figure 22). Be sure the point of penetration allows an 18 inch clearance from the connector to the ceiling. For all Federal Airtights, except the Extra-Large Convection Heater (model FA288CCL), an opening of 30 inches (for a 6-inch stovepipe) must be cut in the wall to maintain the required 12 inches of brick separation from combustibles. For the FA288CCL (and The Sequoia, model FA455 if reducer is not used), a wall opening of 32 inches is required.

CONNECTION TO A MASONRY CHIMNEY (Cont.)

a. Brick chimney thimble assembly (Cont.)

Minimum 3½-inch (4-inch nominal) thick solid bricks are to be used. The fireclay liner (ASTM C35 or equivalent), minimum 5/8-inch wall thickness, must not penetrate into the chimney beyond the inner surface of the chimney flue liner and must be firmly cemented in place. After the assembly is complete, insert the chimney connector in the fireclay liner. Do not push it beyond the inside edge of the chimney liner because this will affect the draw of the chimney.

b. Solid pack chimney with metal supports as a thimble

For the method of installation to a masonry chimney shown in Figures 24 and 25, it will be necessary to purchase an 8 or 10-inch inside diameter 12-inch long section of prefabricated solid pack chimney listed specifically for use as a wall pass through (if using 6-inch stovepipe, an 8-inch inside diameter chimney section is required for use with 8-inch stovepipe) to use a thimble. Purchase a wall spacer, trim collar and wall band that are manufactured to fit the chimney section you purchase.

The safety features of this system are: the 2-inch air space between the chimney section and combustible wall, and the 1-inch air space around the chimney connector as it passes through the chimney section to the chimney.

The location of the opening through the wall to the chimney must leave a minimum 18-inch vertical clearance between the stovepipe and the ceiling to prevent the ceiling from catching fire.

Cut out at least a 14-inch square opening in the wall (a 16-inch square opening should be cut out for the Extra-Large Convection Heater model FA288CCL and Sequoia model FA455 if reducer is not used). It may be necessary to cut wall studs and install a header and sill frame to maintain the wall support. The hole in the chimney must have at least a 6-inch (8-inch for the Extra-Large Convection Heater model FA288CCL and Sequoia model FA455 if reducer is not used) diameter fire clay liner or equivalent secured with refractory mortar. If it is necessary to cut a hole in the chimney liner, use extreme care to keep it from shattering.

First, make the frame for the thimble, making certain it is no smaller than 14 inches square (16 inches square for the Extra-Large Convection Heater model FA288CCL and Sequoia model FA455 if reducer is not used), to maintain a 2-inch air space around the chimney section. Attach the wall spacer to the chimney side of the frame. Then insert the frame into the opening, toenailing it to the wall studs. Install the wall band in the framing to secure the chimney section in place. Insert a single section of stovepipe into the chimney through the wall band, making certain it does not protrude into the chimney beyond the edge of the chimney

flue lining. Apply high temperature furnace cement to the end of the chimney section and install it over the stovepipe, through the wall band, and through the wall spacer. Tighten the wall band to hold the chimney section firmly in place and against the chimney. Install the trim collar on the outside of the opening. Check to assure there is a 1-inch airspace between the stovepipe and the chimney section. Also, during installation always check to assure that a 2-inch airspace is being maintained to the wood framing. Do not fill this space with insulation. Insulation in this airspace will cause a heat buildup which may ignite the wood framing.

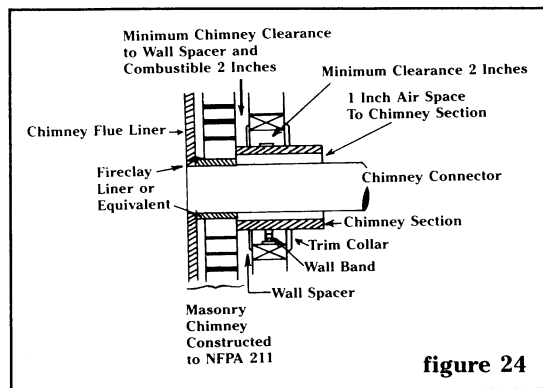

figure 24

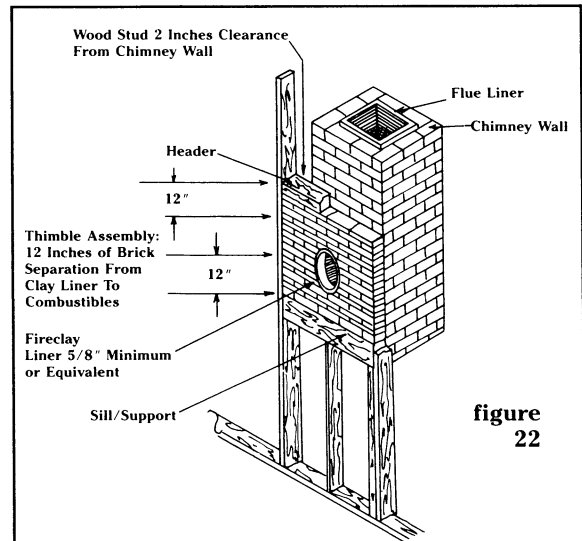

figure 22

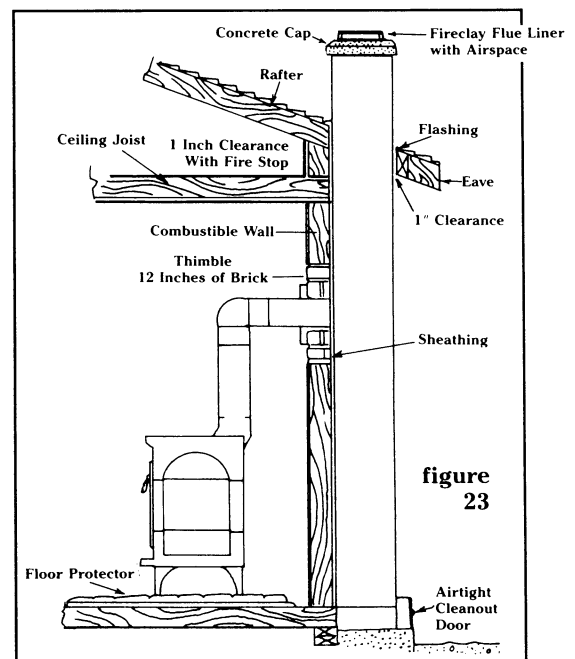

figure 23

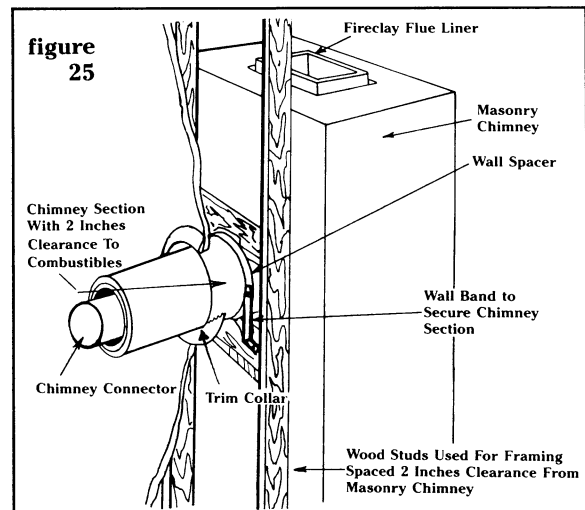

figure 25

CONNECTION TO A MASONRY CHIMNEY (Cont.)

Fireplace Adapter Installation

Because 'Fireplace Adapter' installation is a technical term, let's start by defining it. It means a free standing installation without a shroud, in a fireplace. It is increasingly common to install stoves in existing fireplaces. This can make sense because frequently it is easier and less expensive than installing a new chimney. As well, fireplaces are often sited in appropriate locations for stoves. Each Consolidated Dutchwest stove has been tested for installation in fireplaces. You must, however, proceed with caution.

All fireplaces are not equally safe. Older fireplaces, which predate building codes, particularly may be unsafe. They are not necessarily unsafe but they should always be inspected by a competent person (1st choice - your building inspector, 2nd choice - a chimney sweep) to confirm their safety. They may recommend changes or repair work. This must be done before you install your stove. On newer fireplaces, such concerns are lessened but not eliminated. An inspection should be made and the condition of the chimney should be confirmed as being acceptable. Safety always comes first.

There are two common fireplace adapter installations. The most common is to position the stove on the hearth and vent out the back with the pipe first entering the fireplace opening, then turning up 90 degrees into the chimney and making a positive connection with a block-off plate to seal the chimney. The second type has the stove also sitting on the hearth but with the pipe venting straight up in front of the fireplace and then turning a full 90 degrees and entering the chimney 2-4 feet above the fireplace opening. Venting from the back will usually make for a neater installation, but the latter installation will produce a bit more heat since the pipe will radiate some. **In either case a chimney must be sealed to eliminate the loss of heat and draft pressure.**

In planning a fireplace adapter installation there are several dimensions to take into account. They are: distance from the sides of your stove to right and left side walls; distance from sides of your stove to decorative side trim extending from the face of your fireplace; and the distance from the top of your stove to your mantel. In all cases we have established minimum distances both to combustible surfaces and protected surfaces.

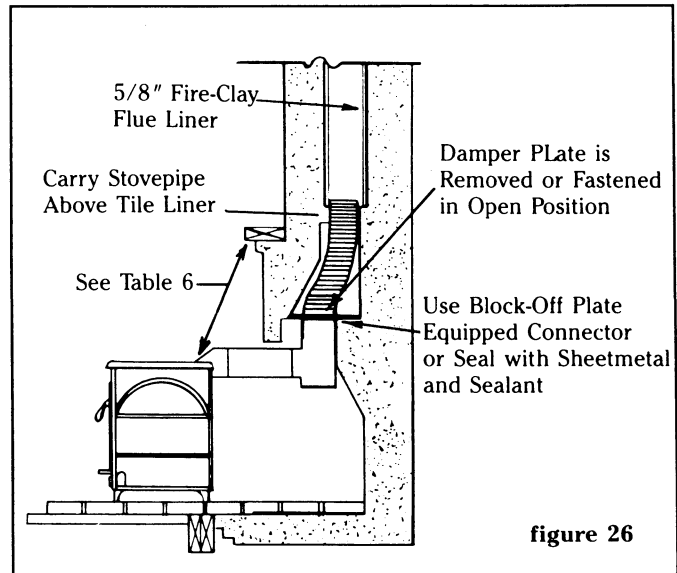

figure 26

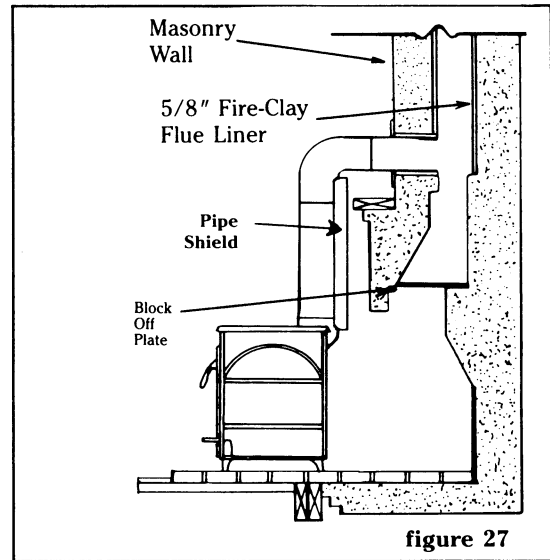

figure 27

FIREPLACE ADAPTER MINIMUM CLEARANCES TO WALLS

Adjusting the height of your stove. Your stove has been tested with the legs provided. However you may wish to raise or lower your stove by using different height legs which are available from Consolidated Dutchwest. Frequently, people will lower the height of their stoves so that the flue outlet in the fireplace adapter installation will be able to clear beneath the top of a low fireplace opening. In using taller legs there are no restrictions.

Table 7

Stove	A	A/P	M	M/P	T
FA207CL	34"	18"	24"	12"	18"
FA209CL	34"	18"	24"	12"	18"
FA211CL	34"	18"	24"	12"	18"
FA224ACL	36"	18"	30"	18"	24"
FA267CL	32"	18"	30"	18"	18"
FA264CCL/R	28"	18"	28"	16"	22"
FA224CCL	28"	18"	28"	16"	16"
FA288CCL	28"	18"	30"	18"	22"
FA455	24"	18"	24"	12"	24"

Minimum clearances from:

A: Side Wall and Ceiling

A/P: Protected Side Wall and Ceiling

M: Mantel

M/P: Protected Mantel

T: Unprotected Decorative Side Trim (extending more than 2 inches from fireplace)

However, in using lower legs, the reduction in leg height may not exceed that amount by which your hearth is raised above the main floor immediately around your fireplace. The raised hearth must also be totally noncombustible. Hence, if your hearth is raised 5" you may reduce your leg height by up to 5". The reason for this requirement is to assure that lowering the stove height does not bring the heater body too close to underlying combustibles. If your hearth is level with the floor you may not use shorter legs, unless your floor is completely non-combustible (no wooden supports under the masonry). Inserts can only be used on a totally noncombustible hearth.

Protecting your mantel. Often a mantel may be positioned too low and may present a hazard. One choice is to remove your mantel. This, however, may have aesthetic implications and may be unsatisfactory. A second alternative is to have a piece of sheet metal custom sized and fitted which can be secured to the underside of your mantel and suspended 1" below it. This can be painted to match the color of your mantel and often is unnoticeable. Commercially available shields are a third possibility. Shields must be at least 47" L x 11" W. Consolidated Dutchwest offers the MP-1 mantel protector. Non-combustible mantels need not be shielded.

Is your chimney lined? Most new homes and many older homes have a chimney liner. What is a chimney liner? Chimneys are made of brick. As the chimney is built, a clay liner is fitted into the chimney passageway. It provides a sealed route through

FIREPLACE ADAPTER MINIMUM CLEARANCES TO WALL (Cont.)

which the exhaust will pass. It can be difficult looking into your chimney to see the liner. Usually it begins well above the fireplace opening at the point where the stack narrows. Chimney liner is typically clay (orange) colored. **We do not recommend installing our stove or any stove in an unlined chimney. This can be dangerous because creosote can travel through the cracked joints between bricks or stones and cause a structural fire.** If your chimney is not lined, several types of stainless steel lining are available from Consolidated Dutchwest.

Making a positive connection. When installing a stove into a masonry chimney, it is essential that the pipe and the chimney be properly connected and fully sealed. In most fireplace adapter installations the stove is vented from the back into the fireplace opening with a 90 degree elbow carrying the exhaust up into the stack. A block-off plate is fitted in place of the fireplace damper or, if the damper is not readily removable, just under it. The plate should have a circular hole which corresponds to the size of the stove pipe, so the pipe may pass through that hole and seal it as it does. All seams between the block-off plate and the chimney and between the block-off plate and the stove pipe should be sealed with furnace cement, silicone caulk, or other appropriate sealant. Block-off plates, positive connection kits, and sealant are available from Consolidated Dutchwest.

Why is it important to make such a secure, positive seal? There are three reasons. A poorly sealed chimney installation will cause (1) substantial heat loss, (2) a significant reduction from the stove's draft pressure, and (3) possible leakage of combustion gasses in an improperly drawing chimney. Since the primary goal of most stove installations is to provide heat, you will be invariably more satisfied with your stove's heating output if the chimney is properly sealed. A reduction in chimney draft, due to a poorly sealed chimney connection, is not always apparent. Frequently a stove in such a circumstance will burn wood readily with excellent output and appear to be operating perfectly. However, when coal burning is attempted, the draft will often be too weak to sustain a prolonged, hot fire. Proper sealing of all pipe and chimney connections will usually remedy this problem.

HEARTH EXTENSIONS FOR FIREPLACE ADAPTER INSTALLATION

Normally a hearth will be wide enough to accommodate the minimum protected floor dimensions required for an adapter stove installation. However, the depth may be insufficient to fully protect the area in front of your stove. If such is your case, you may make up the shortfall by adding a prefabricated hearth extension which has a thermal conductivity of $K=0.84 \text{ BTU IN/FT}^2 \text{ HR } ^\circ\text{F}$ or less to the front of your fireplace or increasing the size of the hearth itself. Hearth extensions are available in a range of sizes and shapes and in a variety of colors. As an alternative, you may position your stove further into the fireplace in order to give you more clear hearth in front of the stove. This can be an acceptable solution. However, remember that the further a stove is into the room, generally the more heat it will provide. Hearth rugs, while attractive, do not meet the code requirements as hearth extensions, so these may not be used in place of a non-combustible hearth. Hearth rugs are used to protect the floor from ashes and to give a richer, finished appearance to the stove setting. Both hearth rugs and hearth extensions are available through Consolidated Dutchwest.

FIREPLACE ADAPTER MINIMUM HEARTH EXTENSIONS

Table 8
Stove

	A	B	C
FA207CL	16"	8"	8"
FA209CL	16"	12"	12"
FA211CL	16"	16"	16"
FA224ACL	16"	16"	8"
FA224CCL	16"	16"	8"
FA264CCL	16"	16"	8"
FA288CCL	16"	16"	8"
FA267CL	16"	16"	8"
FA264CCL-R	16"	8"	16"
FA455	16"	16"	8"

Minimum Hearth Protector
Extensions from:
A: front of stove
B: left side of stove
C: right side of stove

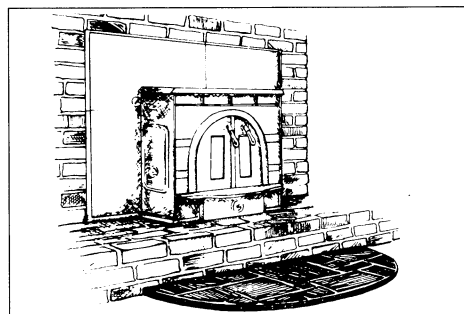

If you plan to mount a fan on the back of your convection heater, it is especially important to clean the fireplace of any ashes or soot, to keep the fan from blowing these into your living space. **Do not mount a fan on the back of a fireplace insert (except FA455).** It is also imperative to make a tightly-sealed positive connection to carry smoke from the stove up into the chimney, so that the fan can't push the smoke out into the living space.

FIREPLACE INSERTS

Our fireplace inserts have been designed to take maximum advantage of your fireplace. A fireplace is almost always a major focal point and our inserts have been designed to belong at the center of attention. A fireplace insert, to be most effective, should be substantially situated on the hearth, rather than embedded in the fireplace. The farther a fireplace insert is set into the fireplace the more difficult it becomes to get heat from the insert out into the room. Each of our fireplace inserts sits only about 2-3" into the fireplace. Most of the insert is on the noncombustible hearth where it can heat best and provide a cooking surface. For details on fireplace insert installation, see the guidelines provided in the "Fireplace Adapter" section.

Here are some frequently asked questions about fireplace insert installations:

Can I seal the shroud on the fireplace front rather than make a positive connection between the fireplace insert's pipe and the chimney? No. Current NFPA and many local codes now require a positive connection. Consult your building code inspector for regulations concerning positive connections which apply in your area.

Can I install my Federal Convection insert in a zero-clearance fireplace? Yes. We have had our fireplace inserts tested for installation in zero-clearance fireplaces. You **must** make a positive connection from the stove using stovepipe to the chimney

Here are some frequently asked questions about fireplace insert installations: (continued)

outlet at the fireplace's firebox. Sealing the shroud along the face of a zero-clearance fireplace does not constitute a safe or approved form of installation. Next, you must be certain that the plates surrounding the insert do not block off the circulating air openings on the zero-clearance fireplace. Since these air openings help cool the fireplace, blocking them off can lead to dangerous overheating. Do not install any insert in a zero-clearance fireplace if it obstructs these air vents. It is also necessary that your fireplace be vented through a chimney meeting building code requirements for venting a stove.

How can I tell if my fireplace is a zero-clearance? Such fireplaces are normally only found in newer homes. They (and their chimneys) are made primarily of metal and carry somewhere on the interior of the firebox a safety listing label which will identify them as a zero-clearance fireplace. Usually they are built directly into a combustible wall with no clearances observed (hence the name). If in doubt, a building inspector or chimney sweep should be able to immediately identify your type of fireplace.

FIREPLACE INSERT CLEARANCES

A fireplace insert installation has clearances to be observed just as free standing and fireplace adapter installations do. Crucial clearances for fireplace inserts are (1) distance to side walls, (2) distance to mantel, and (3) distance to decorative side trim extending from the face of the fireplace.

Note about decorative side trim: Rounded molding normally found on the face of a fireplace which extends 2" or less from the fireplace front usually does not present an issue. Trim which extends more than 2" however is subject to trim clearances. Such trim may be shielded if necessary.

Table 9 Clearances

Insert#	A	A/P	M	M/P	T
7 (A,B)	28"	18"	28"	16"	22"
8 (A,B,C)*	28"	18"	28"	16"	22"
9 (B,C)	28"	18"	30"	18"	22"
11B	24"	18"	24"	12"	24"

*includes 8A-R, 8B-R, 8C-R

Minimum clearance from:

- A: Side Wall
- A/P: Protected Side Wall
- M: Mantel
- M/P: Protected Mantel
- T: Unprotected Decorative side trim

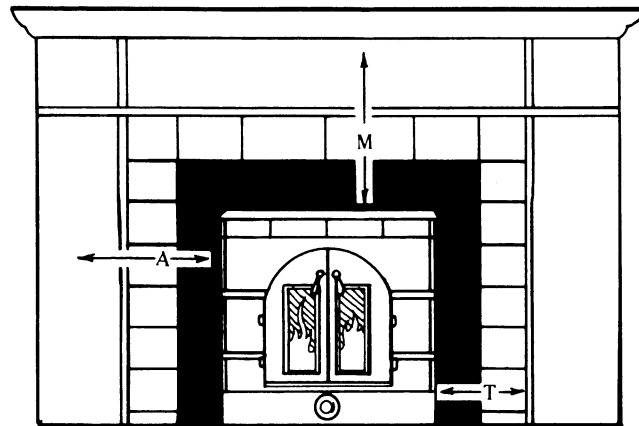

Floor Protector Minimum Extensions

Stove	A	B	C
All Inserts (except right-side loader)	16"	16"	8"
Right Side Loaders	16"	8"	16"

Minimum Hearth Protector Extensions from:

- A: Stove Front
- B: Stove Left Side
- C: Stove Right Side

Protecting your mantel. Often a mantel may be positioned too low and may present a hazard. One choice is to remove your mantel. This, however, may have aesthetic implications and may be unsatisfactory. A second alternative is to have a piece of sheet metal custom sized and fitted which can be secured to the underside of your mantel and suspended 1" below it. This can be painted to match the color of your mantel and often is unnoticeable. Commercially available shields are a third possibility. Shields must be at least 47" L x 11" W. Consolidated Dutchwest offers the MP-1 mantel protector. Non-combustible mantels need not be shielded.

OPERATING YOUR STOVE OR FIREPLACE INSERT

All Federal Airtight stoves and fireplace inserts have been built to be operated with several goals in mind. These goals are:

- 1) optimize safe operation
- 2) minimize fuel usage
- 3) maximize heating output

Whether these goals are achieved in your setting will depend in substantial part on how you install and run your stove or fireplace insert. We have provided the keys. Everything you need for successful, safe, and efficient operation is built in. It is now up to you. No special skills are required although a good dose of common sense will make operation of your stove more satisfying. Be sure to read these operating instructions and the installation instructions in the previous sections carefully. Retain them for future use. Understanding these instructions will enhance stove operation.

CONTROLLING YOUR STOVE OR FIREPLACE INSERT

On each Federal Airtight, there are three air supplies. These air supplies are your main controls over firing and the rate of combustion of your fuel. An optional flue damper, inserted in the first length of stove pipe or as part of the flue collar, can provide an added degree of control over the exit pace of the stove exhaust. A flue damper is highly recommended.

Air supplies: All Federals except the FA267CL have three dial dampers (FA267CL owners should refer to their assembly instructions for details about their air supplies.)

- 1) The dial on the ash drawer is the underfire air, used to start both wood and coal fires, to achieve peak output from wood fires in model FA455, and maintain coal fires.
- 2) The air supply on the loading door is the overfire air. This is typically used to maintain wood fires and to help with secondary coal burning.
- 3) The dial damper on the stove sides (above the side door on 455, 224, 264, 264R, 267, and 288 models) is used to feed additional, preheated combustion air to the position just below the combustor. This further improves the stove's efficiency by helping to burn off an even greater percentage of the wood smoke. This should be closed during coal fires and slow-burning wood fires.

Operating Your Air Supplies: You will be able to control the amount of heat your stove produces, the burn time you will get on a load of fuel, and your stove's overall efficiency through the 3 air supplies. The more air you let in the faster your fuel will burn. Generally speaking, the higher the burn, the less efficient it is.

Each dial damper is fitted with a square steel head onto which your door handle will fit. To close the dampers, rotate in a clockwise direction until the damper is tightly sealed. Open by rotating it in a counter-clockwise direction.

Typical settings of the underfire and overfire air dampers (the main variables in starting and maintaining a fire) will vary according to the fuel used and the amount of heat you wish to generate. Heating output can be increased rapidly by opening the dampers more. However, the dampers should be mostly closed to maintain an overnight fire.

Typical settings are:

**Coal fire: underfire air 1-3 turns open
overfire air ¼-½ turns open or closed**

**Wood fire: underfire air closed
overfire air 3-4 turns open (1-2 turns open for Model FA455)**

When first using the stove, keep track of how many turns open you have set your dampers. You will quickly find that a specific air setting will give you a fixed amount of output. It normally takes about 10 days to determine optimum settings for your installation, as each is different. Remember typical settings are average settings. You may require different damper settings depending on heat output, burn time, draft requirements, etc.

In efficiency testing, the combustor air supply was found to increase the stove's efficiency during high and medium burns. It is necessary that the combustor receive additional air during these burn rates as there is not enough left over from the initial combustion (of the wood in the firebox) to aid the combustor in the burning of the gasses. For wood fires that last about 6 hours or less (medium or high burns), the combustion air dial damper should be opened 1 or more turns. This damper should be closed tightly when maintaining an overnight burn with wood or during the later part of a wood burn cycle.

Rules for Using Air Supplies:

- 1) Do not assume you need a large quantity of combustion air, especially if you have a good draft. When burning wood especially, you will not need much air.
- 2) Trial and error will give you the best settings for your particular installation. By keeping track of the various air settings and resulting heat, you will come to the appropriate setting to meet your heating goals.
- 4) **DO NOT OPERATE THE STOVE WITH THE ASH DOOR OPEN. THIS CAN LEAD TO EXTREME OVERFIRING. OVERFIRING A STOVE IS DANGEROUS.**

Draft Control: Optional Stove Pipe Dampers: The performance of each type of Federal Airtight stove can be enhanced by the addition of a stove pipe damper in the first length of pipe exiting the stove or in the flue collar that is used with the stove. Using a stove pipe damper is particularly helpful in installations with strong drafts. Closing the damper will reduce the amount of exhaust from the stove and increase the amount of heat that stays in the stove and that is transferred to the room. It will also improve burn times. We recommend them highly, and some states require them. Check with your local building inspector.

Consolidated Dutchwest offers separate dampers for mounting both in pipe and in oval-to-round adapter/dampers which replace the oval flue collars normally provided. Oval dampers are also available to fit into the oval flue collars. The following is a list of Federal Stoves and adapter/dampers which have been designed to fit them. Note that adapter/dampers for inserts are also

Draft Control: (continued)

available. These dampers include an arm, lever, and brass handle, and are operated externally from in front of the shroud through a bolt hole provided on the shroud. They replace the function of most fireplace dampers, which are controlled by an arm inside the fireplace opening, and which are usually removed to install positive connections.

Table 10
Stove

Stove	Appropriate Adapter
FA207CL	Mount 6" stove pipe damper in pipe
FA209CL	Mount 6" stove pipe damper in pipe
FA211CL	Mount 6" stove pipe damper in pipe
FA224ACL	FA729 - 6" Oval to Round Adapter with Damper
FA224CCL	FA729 - 6" Oval to Round Adapter with Damper
FA267CL	FA729 - 6" Oval to Round Adapter with Damper
FA264CCL/R	FA729 - 6" Oval to Round Adapter with Damper
FA288CCL	FA727 - 8" Oval to Round Adapter with Damper
FA455	FA727 - 8" Oval to Round Adapter with Damper
7A, 7B Inserts	FA528 - 8" to 6" Oval to Round Adapter
8A, 8B, 8C Inserts	FA741 - 6" Adapter/Damper for Inserts
9B, 9C Inserts	FA736 - 6" Adapter/Damper for Inserts
11B Insert	FA750 - 8" Adapter/Damper for Inserts
	FA724 - 8" Oval-to-Round Adapter
	FA528 - 8" to 6" Oval-to-Round Adapter

OR oval damper on standard flue collar in low clearance fireplace installations.

The Bypass Gate: Another important element in controlling the air flow within the stove is the bypass gate. The bypass gate is operated from the left side of the stove (except for the FA264CCL/R, where it is operated from the right side), by use of a brass handle. The small, square-headed operating rod, located just behind the combustor air damper, is rotated to open and close the bypass gate. Unlike a damper, the bypass has only two positions; open or closed. Rotate the handle clockwise to open the bypass gate and counterclockwise to close it (reverse order for right side loader model FA264CCL-R).

The bypass gate MUST be open during the following situations:

- 1) When starting a fire, in order to create a draft.
- 2) When opening any of the stove's side or front doors.
- 3) When using a firescreen to burn an open fire. Failure to open the bypass gate in this and the above circumstances will lead to heavy smoking in the room, because the smoke will be much more easily pulled out through the open door than up to the chimney through the combustion chamber
- 4) When reloading your fire, for approximately 5 minutes.

The bypass gate should be closed after starting a fire when the catalytic combustor has been activated and the temperature on the probe thermometer reaches about 500 degrees F.

Maintaining Door Locks In Adjustment: Precision control over firing through use of the air supplies requires your stove to be airtight. From time to time your door locks may come out of adjustment. Your door locks have been threaded through the doors. Your doors actually tighten/loosen as they are turned. If the lock is not providing a positive 'tight' seal, rotate the lock shaft 1 turn counter-clockwise to tighten. If still not tight, continue to rotate additional turns as necessary. If the lock is too tight, turn clockwise as many turns as necessary to obtain the right fit. Maintenance of a tight seal on the doors ensures precision control over firing. Very occasionally, it may be necessary to reset the position of the catch on the stem. An allen wrench has been provided for loosening and retightening the catch mechanism. When retightening the set screw with the allen wrench, be sure it lines up against the flat side of the door lock bolt.

Maintaining Airtightness: Each Consolidated Dutchwest stove is airtight. However, over time, cemented seams may deteriorate. Occasionally, some cement may loosen when the stove is in transit. If your stove is running too fast, taking the following measures may remedy the problem:

1. To find low spots in door gasketing, close each door on a slip of paper and attempt to pull the paper free. If the paper is freed without tearing, the gasket isn't snug enough at that spot. Try adjusting the latch (see above). If the door is already as tight as it will comfortably go, either replace the gasketing (see figures 28 thru 30 below) or tug out the existing gasket and pack more cement into the channel behind it. This will push the gasket outward and bring it into contact with the door frame.

Figure 28

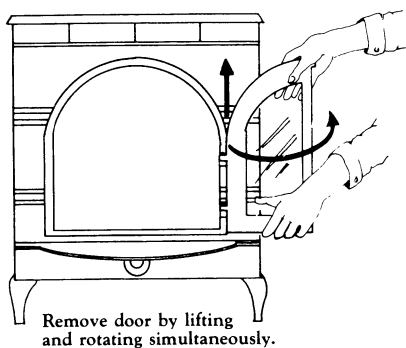

Figure 29

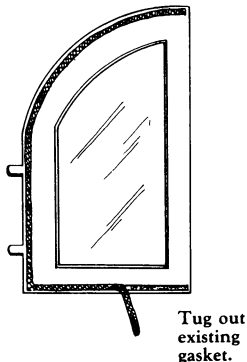
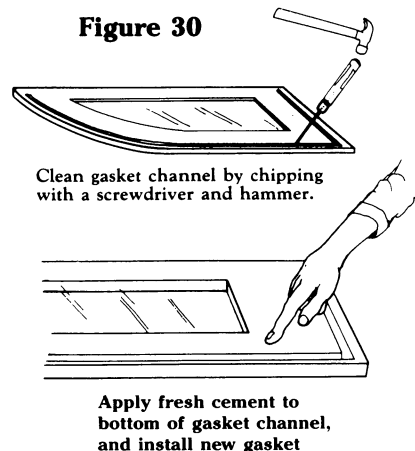

Figure 30



Maintaining Airtightness: (Continued)

Gasket Dimensions

Should you need to replace any gasketing, the following chart shows the amount and diameter that is needed. Use only Consolidated Dutchwest replacement gaskets, available in kit #GK99 (see main catalogue for current pricing).

Table 11

Stove Model	Side Door	L. Main Door	R. Main Door	Front Door	Ash Door	Cook Top	Window Opening	Catalytic Bypass
FA207CL	—	—	—	½" x 39"	½" x 28"	¼" x 31"	⅝" x 20"	⅜" x 25"
FA209CL	—	—	—	½" x 39"	½" x 28"	¼" x 31"	⅝" x 20"	⅜" x 25"
FA211CL	—	—	—	½" x 44"	½" x 36"	¼" x 31"	⅝" x 26"	⅜" x 25"
FA224ACL	½" x 39"	½" x 35"	½" x 22"	—	½" x 32"	¼" x 31"	⅝" x 43"	⅜" x 25"
FA224CCL	½" x 39"	½" x 35"	½" x 22"	—	½" x 32"	¼" x 31"	⅝" x 43"	⅜" x 25"
FA264CCL	½" x 39"	½" x 36"	½" x 24"	—	½" x 36"	¼" x 31"	⅝" x 53"	⅜" x 25"
FA267CL	½" x 39"	½" x 36"	½" x 24"	—	—	¼" x 31"	⅝" x 53"	⅜" x 25"
FA288CCL	½" x 46"	½" x 40"	½" x 28"	—	½" x 43"	¼" x 31"	⅜" x 60"	⅜" x 37"
FA455	½" x 42"	—	—	½" x 60"	½" x 40"	¼" x 40"	⅞" x 51"	⅜" x 37"

* (total)

The cook top frame on the FA211CL is sealed with a ⅞" x 42" section of gasketing.

Glass panels are sealed into their frames with ¾" flat fiberglass rope gasketing. Length is same as specified in "Window Opening" column above.

All rope-type gasketing used in Consolidated Dutchwest stoves is made of fiberglass.

2. To find leaks in external stationary seams, build a medium sized fire with the flue damper and bypass gate open. Then close all air intake dampers. Trace each seam with a candle, cigarette, incense, etc. and note any spots where smoke is drawn in. When the stove has cooled, patch these spots with stove cement. Allow 24 hours for the fresh cement to dry. On convection models, smoke coming from the convection ports indicates an internal seam leak which can be located and repaired as follows: Remove the rear and side half walls inside the firebox (refer to the stove's assembly instructions parts diagram for part identification). Lift the grate frame from the firebox bottom. Block or tape over the convection inlet and outlet ports and turn on the blower (if there is no blower, substitute a hair dryer blowing in through the blower port). This raises the air pressure in the convection chambers. Next, trace the seams inside the firebox with a cigarette, etc., and note any spots where the higher pressure in the convection chambers leaks into the firebox. Clean any loose material off these spots with a wire brush and patch with stove cement. Allow the fresh cement to dry for 24 hours before firing the stove.

Care and Maintenance of Your Blower: The blower sold with Federal Airtight convection models has been designed to provide many years of trouble-free service. In order to obtain the maximum life we suggest that you perform the following maintenance procedures at the beginning of each heating season:

1. Unplug the blower and remove from the stove.
2. Carefully vacuum the accumulated dust from the blower.
3. Permanent sintered bronze sleeve bearings with lubricant oil reservoirs are built into motor, therefore there is no need to add oil.
4. Re-attach the blower to the stove and plug in.

“CURING” YOUR STOVE

Your first few fires should be small to medium in size and wood should be your fuel. Cast iron needs a few milder fires to 'cure' (reach its maximum strength), so you should not build an intense fire the first few times out. This could crack a casting. Build up each succeeding fire a little hotter. After 4 or 5 fires your stove will be 'cured'.

The paint and cement in our stoves also have a curing cycle. There will be a slight odor at the time of curing which is normal. We suggest you burn the stove in a well ventilated area in your home or outdoors with a few sections of pipe on the stove. If you choose to burn the stove outdoors, consult local officials for applicable burning regulations.

The following are recommended probe thermometer temperatures and times involved to reach these temperatures while curing your stove. The dial dampers will have to be adjusted to reach and maintain these temperatures. Remember, the more air that is fed to the fuel, the more heat generated. If the temperature is too low or too high, adjust the dial dampers as necessary.

First Fire: Allow 1 hour to achieve 300 degrees. Maintain 300 degrees for 1 hour and allow fire to burn out.

Second Fire: Allow 1 hour to achieve 500 degrees. Maintain 500 degrees for 2 hours.

Third Fire: Allow 45 minutes to achieve 500 degrees. Close bypass gate so gasses are routed through the combustor. Allow 15 minutes to achieve 800 degrees. Maintain 800 degrees for 3 hours.

Fourth Fire: Allow ½ hour to achieve 500 degrees. Close bypass gate. Allow 20 minutes to achieve 1200 degrees. Maintain 1200 degrees for 4 hours.

LOADING, STARTING , AND MAINTAINING A COAL FIRE

Wood fires and coal fires are loaded, started, and maintained in different ways. The following section is divided into two parts. The first deals with coal fires, the second with wood fires. Read these instructions carefully for a complete understanding of how to run your stove. Failure to follow these operating instructions may result in damage to your stove, void the warranty, or even result in a serious chimney or house fire.

Coal: Each Federal Airtight Stove loads coal through the front door(s). A deep coal bed is required. When possible, you should try to maintain a depth of 6" of coal in the coal bed. To maintain a coal fire, shaking the coal is required every 5-12 hours, depending on the size of your stove and the level of firing.

Note about coal burning: Successful coal burning requires a 30-40 degree F difference between your house temperature and the outside temperature. A substantial difference in temperature enhances draft. A small difference reduces draft. All Consolidated Dutchwest stoves that burn coal also burn wood. If you have trouble maintaining a coal fire, and the weather is still relatively mild (40 or 50 degrees F), wait for a very cold day to burn coal. We suggest as a rule of thumb, that wood be burned early and late in the season and coal, if you choose to burn it, be burned November to March, depending on your location.

Sizes of Coal: There are three sizes of coal commonly used in coal stoves. They are (1) pea coal - very small (3/8" - 3/4"), (2) nut coal - medium sized (¾" - 1½"), and (3) stove coal - larger coal (1½" - 2¾"). We suggest you either use nut or stove coal, and in general have found that stove sized coal delivers the best performance in our stoves once a fire is established. It's often easier to start a fire with nut coal. Anthracite (hard) coal is preferable to bituminous (soft) coal. **Do not burn cannel coal. It gives off gasses which are potentially explosive and is therefore very unsafe.**

To Start A Coal Fire: All coal fires are started with wood, preferably hardwood. Customers who try to start coal fires with coal are in for a frustrating time.

Step 1. Remove the grate covers from their position on top of the shaker grates. These should be kept in case you want to use them for wood burning in the future. Set all necessary coal grate parts in place. In the case of the FA207CL, FA209CL, and FA211CL you need only set the drop-in coal grate front in place. For all 224, 264, 288, and 455 series stoves, you have two coal grate sides and a coal grate front to set in place. Model FA267CL is not designed to burn coal. In every case, this takes only a few moments. Do not try to set any of these parts in place once the fire is underway! **If your catalytic combustor is in place, remove it. It's located just below the polished cooktop. Simply lift it out (remove only when stove is cold). We have provided a cast iron strainer with some models to set in place of your combustor. This strainer will become very hot during firing and will enhance secondary combustion of any unburnt byproducts of coal combustion. It is important to remove your combustor, as smoke from coal fires contains chemicals which can coat the combustor and make it inoperative. Do not run coal fires in your stove while the combustor is in place. In some installations, because of poor draft, you'll need to omit the strainer.**

Step 2. Open the bypass gate (turn clockwise on stoves with the rod exiting the left side. Turn counter-clockwise on stoves with the rod exiting the right side). This is essential. This minimizes draft resistance and ensures your stove will not smoke when the doors are opened. If you attempt to open the doors while the fire is going and the bypass is closed, your stove is almost certain to smoke. This is dangerous. The enhanced draft experienced when the bypass is open makes fire starting very easy.

Step 3. With the coal grate parts in place, go about organizing a normal wood fire. Use paper, kindling, and larger pieces of wood to create a combustible mass.

Step 4. Before lighting the fire make sure the side door (if you have one) is closed. Close the overfire air supply as well. Be certain the bypass gate is open. If you have a stove pipe damper or an adapter/damper make sure this is open. Close the third air inlet damper. Open the underfire air supply approximately 4 full turns. Light the fire and immediately close the main door(s). With the bypass gate open and the stove sealed except for the underfire air which is approximately 4 turns open, a bellows effect is created which will very quickly bring your fuel to a full burn. Permit it to burn for 5-10 minutes, then add additional larger wood. Within 10-30 minutes of starting you should be able to add coal.

LOADING, STARTING, AND MAINTAINING A COAL FIRE (continued)

Step 5. Once all fuel is well engaged, begin to add coal through the front door(s). At first add a layer of about 1-2 inches. Wait 5-10 minutes or until the coal is fully engaged and repeat the process. After adding coal three times then add as much more coal as the coal basket will hold but being careful not to smother the fire. **Close the bypass gate at this point. This will reduce the draft pressure, but will begin to circulate smoke, flame, and heat up through the extended baffling system.**

Step 6. If you have installed a stove pipe damper - at this point you may want to partially or completely close it. The effect of a partially closed pipe damper is to reduce the rate of flue exhaust. With the damper at least partially closed, heat tends to be retained in the stove longer while at the same time secondary combustion tends to be more complete. Note that even when the stove pipe damper is fully closed the pipe remains 30% open, because of the openings provided in the face of the damper and space around it. **DO NOT EVER OPEN THE STOVE DOORS WHEN THE PIPE DAMPER OR BYPASS GATE ARE CLOSED. SMOKE WILL COME OUT OF THE DOORS IF THE FLUEPATH IS RESTRICTED WHEN THE DOORS ARE OPENED.**

Step 7. Once the coal fire is well engaged, reduce the underfire air supply from four turns back to about 1-2 turns open. Now open the overfire air $\frac{1}{4}$ - $\frac{1}{2}$ turn. After reducing the underfire air it will take about 30-45 minutes for the stove to assume its mature operating temperature. The temperature can be increased/decreased by further opening/closing of the underfire air. During a mature coal fire the temperature showing on the probe thermometer will range from 450 to 750 degrees. Temperatures (with coal only) above 900 degrees are an indication of over-firing. Be careful if reducing the underfire air opening below $\frac{1}{2}$ turn as this may lead to putting the fire out. Opening the overfire air damper too much can have the same effect.

Step 8. When burning coal it will periodically be necessary to shake the coal bed down. Because coal has a high ash content (higher than wood) the coal ash must be shaken out or else the fire will suffocate in its own ash. In general, if convenient, the fire should be shaken every 4-6 hours. However, it is possible to go 8, even 12 hours without shaking without detriment to the fire. Maximum time between "shakes" will vary among installations. **Before shaking, be certain the ash door is closed as hot coals may fall out.** The main doors should also be closed because of dust raised during shaking.

About Rotating: When shaking, shake gently. Too vigorous shaking may needlessly disrupt the coal bed. If, when shaking, a rotating section jams, wait an hour or so. Normally the jammed pieces will be consumed (burned) during that time and the grate will be freed up. **Do not use excessive force to free a jammed grate. You will break it.** When rotating the grate sections, their range of motion is 90 degrees. However, for ordinary shaking during an ongoing fire the rotating sections should be rotated no more than 45 degrees. Rotate a full 90 degrees only when you wish to dump the coal bed. Otherwise, you will dump (and waste) coal. Rotating grates are rotated by using a grate handle provided with your stove. Simply slip the grate handle onto the ends of the grate protruding from the side of your stove, then turn them back and forth. Do not shake down all the ashes. Stop shaking after a few red embers are shaken into the ashdrawer. This will protect the grates and provide a hot bed for refueling.

Step 9. To reload a continuing coal fire, first reopen the underfire air supply to 3 turns open. Wait a few minutes for the temperature of the coal bed to increase. Shake gently. Open the bypass gate and any flue or chimney damper(s). Immediately add 1-2 inches of coal and repeat steps 5 and 6. If the fire has burned too far down, and you think that you may lose it, add coal after heating the bed but BEFORE shaking.

Removing Coal Ash: Coal ash will accumulate rather quickly. It will be necessary when burning coal to empty your ashdrawer at least once a day. Coal ash may contain hot coals and should be treated with extreme care. Therefore we suggest emptying the ashdrawer before shaking and reloading. New ash may then cool before the next shake. Coal ash must be placed in a fireproof container or disposed of in another safe manner. Coals can remain hot for a very long time—sometimes as long as a day, so you must be **certain** that they are **completely** cold before you transfer them to an ordinary container. Consolidated Dutchwest offers an ash or coal container (AC1) which is ideal for the purpose. **Coal ash may not be used as fertilizer. It contains minerals that will kill plants.**

LOADING WOOD, STARTING & MAINTAINING A WOOD FIRE

Be sure to follow the operating instructions carefully. Failure to follow instructions may result in damage to your stove, void the warranty, or even result in a serious chimney or house fire.

Wood: Most Federal Airtight Stoves load wood from both front and side. Those stoves that have both front and side door loading are usually easier and more convenient to load from the side. Experience can be your guide. Loading through either door works fine although longer logs can be loaded through a side door if your unit has one. Models FA207CL, FA209CL, and FA211CL are deeper than they are wide and thus load quite easily from the front.

To Start a Wood Fire: Most of us have experience starting a wood fire. Starting a fire in a wood stove is not so different from a fireplace or a campfire.

Step 1. Make sure your stove is set up for wood burning. Your catalytic combustor should be set into the top of the stove in the round space provided just beneath the removable polished top. **Remove the cast iron strainer sitting in the combustor space.** That's only for coal burning (it will interfere with the catalytic combustor). If your stove is an FA207CL, FA209CL, or FA211CL you also need to remove the drop-in coal grate front. If your stove is from the 224, 264, or 288 or 455 series then you need to be sure all coal burning grate parts have been removed. There are 2 coal grate sides and the grate front. The grate front may be left in place to keep the logs away from the front doors (load from the side). The FA267CL also has a front grate which is useful in keeping wood off the front doors. All stoves, except 267, come with grate covers which were found to marginally improve stove efficiency (by about 2-3%). Please see the assembly instructions that came with your stove for more information about these grate covers.

Use small pieces of wood—preferably soft woods—as kindling, with your main fire to be hardwood—oak, ash, hickory, etc. Do not burn anything but real wood in your stove. Things like plywood, pressed board, waferboard, chipboard, masonite, etc., contain glues which form toxic gasses when burned. Your combustor is not meant to deal with these gasses. Never burn pressure treated lumber under any circumstances, as it contains copper chromium arsenate, a form of arsenic, which is extremely toxic.

LOADING WOOD, STARTING & MAINTAINING A WOOD FIRE (continued)

Step 2. Open the bypass gate, and any flue damper(s). This is very important. It minimizes draft resistance and ensures your stove will not smoke when the doors are opened. If you attempt to open the doors while firing is underway and the dampers are closed, your stove is almost certain to smoke. This is dangerous. The enhanced draft experienced when the dampers are open makes fire starting easier.

Step 3. Using paper, kindling, and large pieces of wood, go about organizing a normal wood fire. Be sure to use sufficient quantities of all materials so the fire has the opportunity to 'catch'.

Step 4. Before lighting the fire, be sure the side door (if you have one) is closed. Close the overfire air supply as well. Check again to see if the bypass gate is open (see step 2 under starting a coal fire). If you have a fluepipe damper, be sure that it is open as well. Open the underfire air supply 3 turns. Light the fire and immediately close the main door(s). With only the underfire air open a bellows effect will immediately be created which very quickly will bring your fuel to a full burn. Permit it to burn 3-7 minutes, then add additional larger wood. Within 10-15 minutes the fire will be well established.

Sometimes, when a chimney is cold, it will take a little time to warm up sufficiently to draw. Unfortunately, this can lead your stove to "smoke" until it starts drawing. To alleviate this problem, we suggest you roll up a couple of pieces of newspaper, place them on top of the fuel in your stove, and push them toward the stove back. Light these pieces first and close the front door(s). These will heat the chimney sufficiently to start it drawing. Through the glass window(s), you will be able to see when the chimney starts drawing the smoke away. Once it does, open the main door(s) and light the rest of the fuel from the bottom. Do not light the main bed of fuel until the chimney begins drawing, and if the rolled paper goes out without creating a strong draw, repeat the procedure.

Step 5. Once the temperature on the probe thermometer (inset in the finished cooktop) has reached at least 600 degrees, close the bypass gate. This will activate the catalytic combustor and force the heat through the stove's baffling system. To ensure the combustor's continued operation, let the temperature approach 800 degrees before changing your air settings.

Step 6. Open the overfire air supply to about one turn open (2 turns open for model FA455). Close the underfire air completely. The volume of fire will be immediately reduced, but the stove will continue to warm up. Continue to control the fire using only the overfire air. For a smaller fire, reduce the overfire air setting. For a larger fire increase the damper setting. If this does not produce a sufficiently hot fire, then reopen the underfire damper a small amount until the fire becomes hotter.

Step 7. If you have installed a stove pipe damper - at this point you may want to partially or completely close it. The effect of a partially or completely closed pipe damper is to reduce the volume and pace of the flue exhaust. With the damper at least partially closed, heat tends to be retained in the stove longer while at the same time secondary combustion tends to be more complete. Note that even when the stove pipe damper is "fully closed" the pipe remains 30% open because of openings provided in the face of the damper and space around it. **DO NOT EVER OPEN THE STOVE WHEN EITHER THE PIPE DAMPER OR THE BY-PASS IS CLOSED. SMOKE WILL COME OUT OF THE DOORS IF THE DAMPERS ARE CLOSED WHEN THE DOORS ARE OPENED.**

Note about operating temperatures: Wood smoke activates the catalytic combustor causing the smoke, creosote, and other by-products of wood burning to ignite. The results are very high temperatures in the combustor. Though operating temperatures of 1400 and 1600 degrees are common, the recommended operating temperature range is 1000 to 1400 degrees to prevent damage to the combustor. Temperatures of 1700 degrees or higher may damage the combustor. High combustor temperatures will frequently be experienced even during slow burning, cooler fires since this kind of burning actually produces more by-products, which are fuel for the combustor. Further note that although the combustor probe set into the cooktop will be registering very high temperatures, the actual temperature of the stove body itself will be much lower. Typically the stove body will be 350-600 degrees.

RELOADING WITH WOOD

Step 8. When you wish to add fuel, follow these steps (1) open the bypass gate (and the stove pipe damper if you have one) and wait 15 seconds; (2) open the door slowly; (3) add fuel. Note that split wood will more completely fill the firebox and hence reduce the frequency of reloading. In the event your wood is not seasoned (dry), it will burn more readily if split.

Step 9. After closing the loading door, check to see if the thermometer is continuing to register at least 500 degrees, the minimum temperature required for catalytic activity. Frequently, the temperature will drop below 500 degrees, particularly if the loading door is open a long time. You may wish to increase the overfire air setting to prompt the fire. If the fire is very weak, you may wish to open the underfire air and/or the by-pass gate to increase the draft. However, this should be done only for very brief periods as the stove may over-fire, sending significant amounts of lost heat up the chimney while wasting fuel.

Removing wood ash: A natural residue of wood burning is wood ash. Such ash may be left to accumulate in the stove without risk to the stove. Ash should be removed, however, if its accumulation is causing a mess. Accumulations of wood ash seem to enhance catalytic activity. This is because wood ash is mainly charcoal and charcoal provides a large percentage of the gasses that the combustor burns most readily. Typically, during wood burning, the ash drawer needs to be emptied once every 1-3 days. **WOOD ASH SHOULD ALWAYS BE DISPOSED OF IN A SAFE MANNER** Ashes should be placed in a metal container with a tight fitting lid. The closed container of ashes should be placed on a non-combustible floor or on the ground, well away from all combustible materials, pending final disposal. If the ashes are disposed of by burial in soil or otherwise locally dispersed, they should be retained in the closed container until cinders have thoroughly cooled. Consolidated Dutchwest offers an ash & coal container (AC1) which is ideal for the disposal of wood ash. **Wood ash may be used as fertilizer.**

BURN TIMES & LONG BURNS

When firing your stove, the volume of heat and the length of your burn time will vary according to the (1) size of your stove, (2) damper settings, (3) volume of fuel loaded, (4) the quality of your fuel, and (5) draft and infiltration rates. In general, the

BURN TIMES & LONG BURNS (continued)

average operating temperatures of a stove will be about 350-600 degrees (temperatures on the front and side of your stove). The probe thermometer on the stove top, however, during catalytic combustion, will register about twice the temperature of the stove body. During coal burning the temperatures recorded on the top will approximate the temperature of the entire stove body.

Here is a guide to your stove's output:

Table 12

Stove	Capacity Wood	Burn Times (hours)	
	Log length	Low	High
FA207CL	13"	5:50	1:15
FA209CL	18"	5:00	1:40
FA211CL	18"	8:25	2:00
FA224ACL	19"	7:45	1:50
FA224CCL	19"	8:25	1:55
FA267CL	22"	11:45	2:25
FA264CCL	22"	9:45	2:30
FA288CCL	25"	13:30	2:45
FA455	23"	9:50	1:24

Note: All burn times are approximate. Installations circumstances and heating requirements will cause burn times to vary widely.

MAXIMIZING YOUR STOVE'S OUTPUT

We have undertaken extensive testing of our stoves to establish combustion efficiency, heat transfer efficiency, overall efficiency, estimated fuel consumption, and BTU ratings with a variety of air inlet and stove pipe damper settings. Here are some conclusions we have reached:

- (1) With a catalytic combustor and a stove pipe damper in place, our stoves can be expected to provide 70-85% overall efficiency (see table 13-Oregon Test Results) — (overall efficiency is computed by multiplying combustion efficiency — 90%-95% — by transfer efficiency — approximately 80%-85%). By this we mean 70%-85% of the heating value of the wood consumed becomes usable heat transferred to the room. This compares with a 40-50% overall efficiency for typical airtight, non catalytic woodburning, and with 0-15% overall efficiency in a fireplace.
- (2) A stove pipe damper increases control over firing, extended long burning, and increases overall efficiency in strong drafting chimneys.
- (3) The presence of a catalytic combustor tends to equalize overall efficiency so that the variation in efficiency between high and low fires is minimized. With non-catalytic airtight woodburning, high fires tend to have high combustion efficiency but poor heat transfer while low fires tend to have very poor combustion efficiency but better heat transfer. It's poor combustion efficiency during low firing in a non-catalytic stove that causes the build-up of creosote in the chimney. This problem is almost entirely eliminated when a combustor is introduced.

EFFICIENCY TESTING RESULTS WITH WOOD

Consolidated Dutchwest has undertaken substantial efficiency tests to provide its customers with the most efficient, clean burning stoves on the market today. Testing was done by Shelton Research, Inc. of Santa Fe, New Mexico in accordance with Oregon Department of Environmental Quality standards to establish combustion efficiency, heat transfer efficiency, overall efficiency, estimated fuel consumption, and BTU ratings with a variety of air inlet and stove pipe damper settings.

A stove's efficiency is measured by how much of the heat energy stored in the wood is transferred into the room. It is computed by multiplying combustion efficiency (the amount of energy produced from the wood) by transfer efficiency (the amount of heat produced from the wood that the stove transfers to the living area).

The following numbers are based on Oregon testing which requires grids of specified fuel be used and testing undertaken at four burn rates. Separate testing (not using Oregon standards) with a full load of typical hardwood at many burn rates indicates substantially higher outputs can be achieved in actual usage. However, most people's heating needs range from about 10,000 to 20,000 BTUs/hour, numbers within the Oregon testing range. Highest efficiencies, frequently over 80% with most models, are almost always achieved with slower-burning fires. Conversely, roaring fires will usually have efficiency levels below the average overall efficiencies shown here.

Table 13

STOVE	AVERAGE OVERALL EFFICIENCY
FA207CL	76.00%
FA209CL	74.00%
FA211CL	76.40%
FA224ACL	79.80%
FA224CCL	78.90%
FA264CCL	78.80%
FA267CL	78.70%
FA288CCL	75.50%
FA455	82.20%

CATALYTIC COMBUSTION

When burning wood, use of the catalytic combustor is essential for high efficiency and clean burning as is required by the new EPA (Federal) regulations. When wood is burned, only a fraction of its energy is turned into heat. The rest goes up the chimney in the form of smoke. It takes a very high temperature of 1100 degrees F to burn the smoke and turn it into productive heat. In non-catalytic airtight stoves, some of this smoke burns during high burns and where additional combustion air is provided. This process is ineffective during medium and low burns, however, because firebox temperatures are not high enough to reach the necessary combustion temperature. These stoves also produce large amounts of creosote during long burns.

The catalytic combustor is coated with precious metals that cause the smoke to burn at only 500-600 degrees Fahrenheit, meaning a more complete combustion process that gives you more heat and a cleaner burn. Even during long burns, when the firebox temperature decreases, the combustor feeds on the smoke to maintain the 500-600 degree combustion temperature. The result is longer burns, more heat per pound of wood, and less creosote if properly used.

Combustor usage: In order to activate the combustor, the bypass gate must be closed to force the smoke up through the combustion chamber. Because this reduces the draft, you should be careful not to close the bypass gate too soon. When starting a fire, even if the temperature probe reaches 600 degrees F within a few minutes, you should let a strong fire run about 15-20 minutes before closing the bypass gate and activating the combustor. If you close the bypass gate too early, you may put out the fire or deactivate the combustor. Thus, a cold stove should be warmed up well before closing the bypass gate.

Remember: The combustor air supply feeds air to the area just below the combustor (between the combustor and the baffle). The combustor's efficiency will be enhanced by fully opening the combustor air dial damper high on the side of the stove during MEDIUM and HIGH burns. It is necessary that the combustor receive additional air during these burn rates, as there is not enough left over from initial combustion (of the wood in the firebox) to aid the combustor in burning off gasses. The dial damper should be closed during low burns (8 hours or more), and during the later part of a burn cycle, because additional air is not needed to create secondary combustion of gasses in the combustor.

Combustor maintenance: The ceramic combustor will enhance your stove's performance, but there are certain characteristics which you should be aware of, and certain precautions you will want to take as follows:

(1) Burning fuels other than natural wood will shorten the combustor's life substantially. If you burn coal or wood that has been treated in any way, the combustor should be removed from the stove. Otherwise, ash, and other chemicals will plug up the combustor and cause its precious metal coating to deteriorate. Colored or coated papers, or papers printed with colored inks, will have the same effect, if burned in large quantities. If you forget to remove the combustor when burning coal, and ash has built up, you can try burning a few high wood fires with the combustor in position to get the ash coating off.

(2) The stove should be operated at probe temperatures between 800-1200 degrees. Temperatures over 1700 degrees may damage the combustor.

(3) If you notice creosote building up in your chimney or pipe, you may be operating your stove in a way that produces creosote (see section on creosote below), or your combustor may be plugged up. Certain woods leave an ash film on the combustor, plugging it up. Periodic inspection of the combustor (at least three times during the heating season) will solve this problem. Remove ash by blowing air through the combustor. Do not push a brush or other object through the cells to clean it as this will scratch off the metallic plating which forms the catalyst.

Catalyst should be removed for inspection as shown in figures 31 through 33.

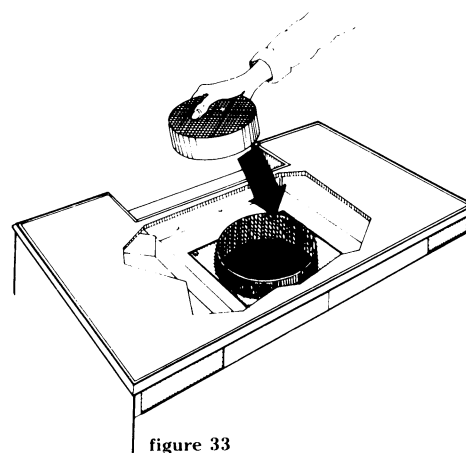
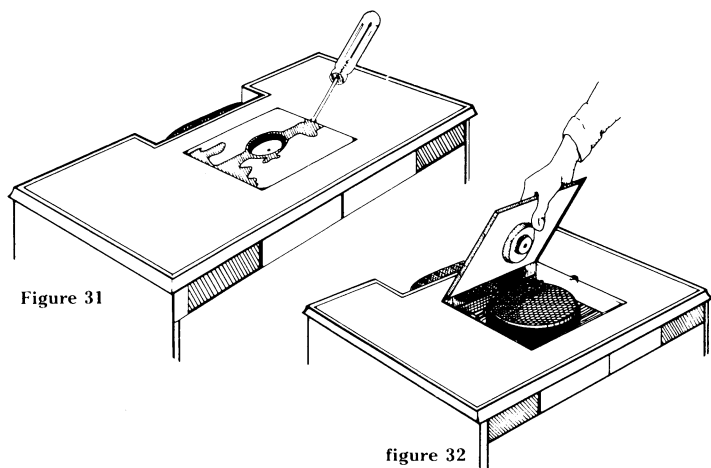

(4) The combustor may glow during the first 1/4 to 1/3 of the burn cycle, but it does not have to be glowing for it to be working. The ceramic substrate begins to glow at temperatures starting at 1200°F. The glowing is not caused by the combustor firing, it is simply a result of it reaching temperatures of over 1200°, just as metal glows when it reaches certain temperatures. During most fires (that is, slow to medium burn rates), the combustor is operating at temperatures between 800° and 1100° and does not glow. Therefore, to determine whether your catalytic combustor is operating, check the reading on your probe thermometer (inset in the cooking top) which measures catalytic temperatures. If it reads 500° or higher, your catalytic combustor is hot enough to operate. If temperatures are lower than this, you should increase the intensity of the fire or reload the stove to keep the combustor functioning.

(5) Catalytic combustors can be defective in two ways. The most obvious is deterioration of the ceramic substrate. This is evidenced by crumbling of the catalytic combustor. Cracks or minor chipping of the combustor will not affect its performance,

CATALYTIC COMBUSTION (continued)

but if sizable portions of it break off, you will need to replace it. The other way a catalytic combustor can be defective is that it does not assist in the burning of gasses. This is a rare occurrence since all are manufactured the same way, so we suggest you call our Technical Service Department first if you believe your combustor is experiencing this problem. Sometimes other factors, such as failure to first heat the stove up sufficiently to achieve 'light-off', will be the problem. Call or write our Technical Department if you have any questions regarding combustor operation and we will provide the guidance necessary to solve the problem. You may feel the combustor is defective, but in actuality the stove is not being operated properly. If we are unable to resolve your problem, we will see that your combustor is shipped to Corning Glass Works for testing and replacement if defective. See page 21 for more information on potential combustor problems.

(6) Combustor Failures: As your combustor nears the end of its expected lifespan of 12,000 operating hours (3 to 6 years for the average user), probe thermometer temperatures during normal firing will gradually decrease. If the combustor is clean and its temperatures no longer rise to 700° after 'lighting off', the combustor is no longer effective and should be replaced.

Warranty Information for Corning 'Long-Life' Catalytic Combustor

Each Consolidated Dutchwest catalytic stove sold in the United States now comes with the new Corning 'Long-Life' catalytic combustor. The 'Long-Life' combustor has twice the expected lifetime of Corning's earlier models, approximately 12,000 hours of use before replacement is needed.

The lifespan of your combustor will be affected by its use. Large fires will consume the catalyst at an increased rate, shortening the effectiveness of the combustor. Original combustor or replacement will be replaced at no cost to stove purchaser for two years from original purchase date if it proves to be defective or fails to maintain 70% of its particulate reduction activity as measured by an approved testing procedure. To report a defective catalytic combustor, please call Team Fireside at **1-800-22-STOVE (1-800-227-8683)**. You may also report a defective catalytic combustor by writing **Consolidated Dutchwest, a Division of V. C. I., Prince Street, Randolph, Vermont 05060**. If you wish to receive a replacement at the time you write, please send us the defective combustor, (catalytic combustors are extremely fragile, and should be packaged and marked for shipment accordingly) plus information as to when, from whom, and which model stove you purchased, plus information as to in what manner it is defective. If you purchased directly from Consolidated Dutchwest and have available a copy of the original paperwork showing your order number, we would appreciate your including that as well. It is necessary to send us the defective combustor as the manufacturer (Corning) requires this under their warranty. We will take care of sending it to Corning and providing them with the information necessary to secure your replacement, if the combustor is found to be defective. Note: To determine if the combustor is defective, read combustor maintenance, page 19 & 20, combustor related problems, page 21 or call Team Fireside.

CREOSOTE

When wood is burned slowly, it produces tar and other organic vapors which combine with expelled moisture to form creosote. The creosote vapors condense in the relatively cool chimney of a slow burning fire. As a result, creosote accumulates on the flue lining. When ignited, this creosote can cause an extremely hot and dangerous fire.

With the catalytic combustor and combustor air to burn off wood smoke and by-products, creosote build-up can be reduced by as much as 90%. Many customers have gone through a number of seasons with very little creosote build-up.

Nonetheless, creosote may build-up, depending on your installation and firing habits. Installations with poor drafts are more likely to create creosote because wood smoke moves very slowly up the chimney and is more likely to cool and condense there.

Stoves set for long burn times (especially those with a poor draft) may also contribute to creosote build-up if the temperature falls below 500 degrees Fahrenheit. In that case you should re-build the fire and temporarily open the by-pass gate to create a stronger draft.

Even when using a catalytic combustor, your chimney and chimney connector must be inspected regularly, at least once every two months in the heating season (more often if experience dictates) to determine if creosote build-up has occurred. If creosote has accumulated, it should be removed to reduce the risk of a chimney fire. Our catalogue includes a selection of chimney brushes which will make cleaning easy.

Combustor Related Problems

PROBLEM

POSSIBLE CAUSE

SOLUTION

PLUGGING (photo 2)

1. Burning materials that produce a lot of char and fly ash.
2. Burning wet, pitchy woods or burning large loads of small diameter wood with the combustor in the operating position without light-off taking place.
3. Combustor not functioning. If proper burning procedures have been followed to no avail, the combustor is not functioning.

1. Do not burn materials such as garbage, gift wrap, or cardboard.
- 2a. Burn dry, seasoned wood
- 2b. Don't place the combustor in operating position until temperatures are high enough to initiate light-off.
3. Replace combustor.

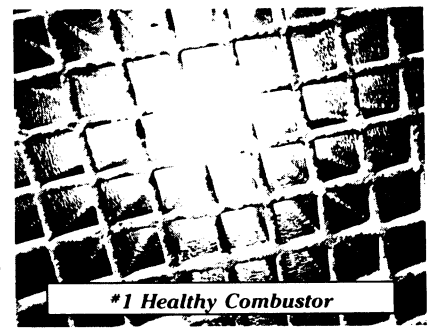

#1 Healthy Combustor

CATALYST PEELING (photo 3)

1. Extreme temperatures (above 1800° F or 1000° C.) at combustor surface can cause the catalyst to peel. Overfiring and flame impingement are primary causes.

- 1a. If peeling is severe, remove and replace combustor.
- 1b. Avoid extreme temperatures and flame impingement.

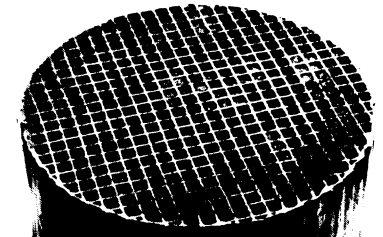

#2 Creosote Plugging

CATALYST DEACTIVATION

1. Burning large quantities of trash, pressure treated lumber, or painted woods.

- 1a. Burn quality woods available in your area.
- 1b. If you decide the catalyst has been deactivated, replace combustor.

CATALYST ASKING

The catalyst is coated with a layer of fly ash or soot which prevents catalytic activity.

1. Accumulation of fly ash.
2. Burning coal causes a sulfur-based compound to coat the catalyst.

1. Brush cooled combustor with a soft-bristled brush or vacuum lightly. At least once per burning season, carefully remove combustor and brush off trailing or downstream face.
2. Revert to burning wood and fire the combustor at elevated temperatures for a period of one hour. (Five-20 minute high-fire start-ups would do it).

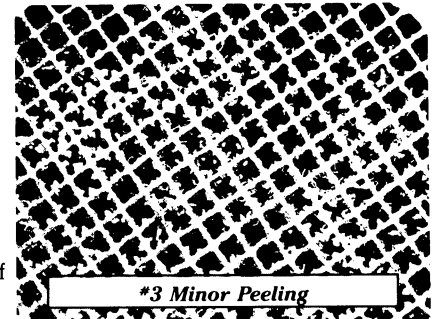

#3 Minor Peeling

SUBSTRATE CRACKING— THERMAL (photo 5)

1. Some minor cracks can result from normal operation, as long as the combustor remains intact.

1. If cracking causes large pieces to fall out, replace combustor.

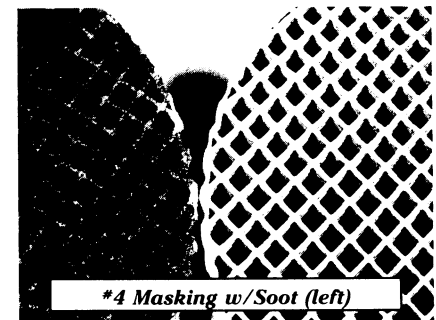

#4 Masking w/Soot (left)

SUBSTRATE CRACKING— MECHANICAL (photo 6)

1. Mishandling or abuse.
2. Distortion of holding collar.

1. Handle with care.
2. Combustor should be held firmly in its can. It should slide easily into and out of the holding collar of the stove. If severe cracking has resulted in loss of large chunks of combustor, replace combustor. Also replace any warped stove parts.

SUBSTRATE RUMBLING

1. Extreme thermal shock. (Combustor being worked too hard).
2. High draft.

1. Bypass combustor when stove is run in high-fire mode.
2. Do not exceed .06" of water draft. Install a manual damper and draft gauge, or a barometric damper.

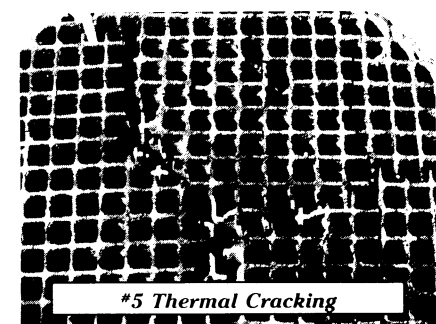

#5 Thermal Cracking

COLOR VARIATIONS

1. Variation in color from combustor to combustor or within a combustion can occur. (New combustors)

1. These color variations are normal and do not affect combustor performance.

CATALYST ABRASION

1. High draft can cause fly ash to grit-blast the surface of the combustor.

- 1a. If more than 1/2" of catalyst (as measured along length of cell) is abraded, replace combustor.
- 1b. Measure chimney draft and control to .06" of water or less.

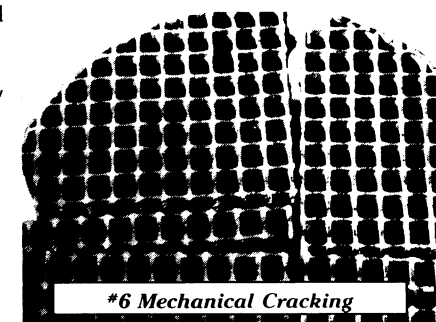

#6 Mechanical Cracking

Trouble-shooting Guide

Each installation is different. From time to time problems may occur. This section is intended to help you self-diagnose any problem you encounter. If you are unable to resolve a problem that arises, you may write or call the Technical Service Department.

The following are problems which may arise, and helpful explanations and/or solutions for them.

1. White spots on stove. The furnace cement we use is manufactured by Rutland. Over time and in moist conditions the furnace cement will bloom (turn white). Any area that turns white should be thoroughly brushed and repainted. Wire brushing will remove the cement so that the spots will not reappear. If you paint over them without first brushing, they will probably reappear later on.

2. Dirty Glass. When burning coal your ceramic glass windows will remain clear. However, when burning wood, particularly during slow firing, creosote may coat the window with a blackish film. This film can be scraped off with a putty knife, cleaned with a chemical solvent (recommended for ceramic glass), or burned off during a high firing.

3. Paint develops a bleached look on sides. Stove paint will lose its pigment at about 1000 degrees F. If the pigment is burned out you are probably over-firing. Repaint and rein in on your heating ambitions.

4. Shaker grate jams. The rocker grates will occasionally jam when coal gets caught between the rocker grate and the fixed center grate section. If one section locks up during shaking, do not try to force it. To do so may break the grate. Rather, wait 45 minutes to an hour and the piece causing the jam will be consumed by the fire, and the grate will be freed up. When shaking, the grate can rotate 90 degrees. However, for ordinary shaking during an ongoing coal fire the rotating grates should only be rotated 45 degrees. A full 90 degree shake will cause the grate to dump the coal into the ash pan and may cause the grate to jam.

5. Low draft. Many problems result from bad draft, including shorter burn times, low heat output, inability to maintain a fire, condensation, and smoking. Here are some of the causes and solution:

a. Your chimney or stove pipe is blocked up either with creosote or some other kind of blockage. You should inspect your pipe or chimney periodically to avoid this problem.

b. A connection between two sections of stove pipe may have come loose. The connections should be sealed with anchor screws to avoid this problem. You can isolate leaking joints with the cigarette test described in paragraph 'g' below.

c. Your pipe installation has too many turns or runs horizontally for too great a distance. Any turn creates resistance to the smoke's path. You should avoid more than two 90 degree turns in any one installation, and any level sections of pipe should be no longer than two feet. It is better to make 90 degree turns in two steps, with two 45 degree elbows to minimize the draft resistance. If you want to increase your draft, and you are stuck with more turns in your pipe than desirable, you can consider extending the height of your chimney.

d. Short stack. Even in installations with a correct pipe configuration, you might still have draft problems if your stack is too short. The minimum height should be at least 18 feet. Also, your chimney should be at least 3 feet above the roof line and 2 feet higher than anything else within a 10 foot radius horizontally.

e. Oversized Chimney. If the area inside a chimney is too large the smoke will disperse and rise slowly, limiting the draft. As a rule, chimney volumes should not exceed twice or 2½ times that of the stoves flue outlet. For a 6" (flue size) stove, the chimney area should be approximately 30 to 65 square inches. For an 8" stove, the chimney area should be approximately 50 to 96 square inches. If the chimney is too large, you can reduce the chimney's interior size by adding chimney liner or help the draft by extending the pipe from your stove well up into the chimney.

f. More than one heating device is vented into the stack. **ONLY ONE HEATING DEVICE SHOULD BE USED PER FLUE.** The draft may be bypassing your stove and drawing through the other device.

g. Your installation and positive connection may be poorly sealed. Particularly if venting into a fireplace, an improperly sealed connection from stove to stack may be permitting the draft to skip the stove and draw through the other openings. Therefore, make sure all connections are sealed tightly. If you're convinced your installation is properly sealed, then look for leaks in the stack itself. In a masonry chimney, look for a poorly fitting ash door in the basement or on an outside wall. Placing a lighted cigarette near connections in your chimney or block-off plate when your stove is in operation can help reveal a leaky connection (the smoke will be drawn in).

h. Undersized chimney. The chimney must have an interior square at least equal to the stoves flue pipe. See section 'e' above. It is a violation of safety regulations to reduce a stove's flue size unless specifically approved by the manufacturer.

i. Tightly sealed house. A stove depends on a house's natural leakage to replace the air it burns and sends up the chimney. If your house is especially well sealed it may prevent this leakage. Test for this condition by cracking open the door or window closest to the stove and noting if this makes a difference in the stove's operation. If it does, you should install an outside air intake to bring the combustion air for the stove from outside the house.

6. Can't get the long burn time. Besides a poor draft, airtightness is also a factor in getting a long burn. **See page 13 "Maintaining Airtightness"**. The wood you burn will also influence your burn time. Softwoods tend to burn relatively quickly. For the best burn times, you should stick to seasoned hardwoods. You may also be trying to get more heat from a 'long burn' than the stove is capable of delivering. One load of wood has a fixed and limited amount of energy stored in it. There will be a big difference in heat output if that energy is consumed over one hour or ten hours. A slow overnight burn should not be expected to maintain a high indoor temperature.

7. Can't maintain a coal fire. In some cases, your stove will burn wood very well but still have trouble maintaining a coal fire. In most cases, this indicates that you still have one of the draft problems mentioned in #5. But there are two other possibilities:

- a. You need at least a 30-40 degree difference between the indoor and outdoor temperature in order to maintain a sufficient draft for coal burning. On warm days, it will be very difficult to maintain a coal fire. It's best to burn wood early and late in the season and coal from November to March.
- b. There are various grades and qualities of coal. If you don't know your supplier well, try a bag of high-grade coal from another supplier. You may have coal with a high percentage of impurities.

8. Not getting enough heat. This situation may be indicative of several things. (1) The area you are trying to heat may be poorly insulated or drafty and may not be retaining heat properly; (2) you may have a draft problem as discussed in #5 which is limiting your maximum firing level; (3) the stove may be undersized for the job at hand.

9. Smoke coming from the surface of a new stove. During the first few burns, the stove paint and furnace cement 'cure' and let off smoke. You'll be able to differentiate this smoke from leakage because paint and wood smoke have distinctly different odors. Some people run their first few fires outdoors to avoid these odors.

10. Stove or stove area is smoking. You should first determine exactly where the smoke is coming from. If smoke is consistently coming out of one part of the stove, one of the seams or the doors (see #12) may be leaking. You can apply fresh stove cement to the seams to patch the leak. However, the fact that smoke is leaking out (instead of leaking in), is also a sign of a draft problem which needs to be corrected (see #5). If the smoke is coming from the pipe area, your pipe connections or block-off plate are probably not sealed or have come apart. These should be resealed or reconnected. When opening the front or side doors, the bypass gate must be opened first. Otherwise the stove will smoke. If the bypass gate is open and the stove is still smoking, then you should check the problems mentioned in #5 regarding bad draft.

11. Downdraft. If you frequently experience downdraft, you probably have a draft or installation problem (see #5). One possible solution is to increase the chimney height. If nearby trees or other obstructions are interfering with your draft, you may need to remove them, or get a regulating device such as the 'Vacu-Stack' downdraft preventer offered in our main catalogue. Smoking related to wind direction or wind speed can usually be solved by a downdraft preventor, while other types of smoking are a sign of an obstruction or other problem described in #5.

12. Doors don't seal properly. Each door is fitted with a threaded door lock. When turned clockwise, the mechanism tightens. Using the removable door handles, rotate the locks 360 degrees to tighten or loosen the latches as necessary. This will keep the door well-sealed. It may be necessary to reset the catch on the threaded stem. An allen wrench is provided for this purpose. In certain situations, the gasketing may also lose its original shape and prevent the door from closing tightly, in which case you should replace the gasketing. Use only Consolidated Dutchwest replacement gaskets, available in kit #GK99 (see main catalogue for current pricing).

13. Can't get enough wood into the firebox. In loading our stoves we suggest you use split wood. It permits the loading of substantially more wood. The AX-1, a heavy-duty maul, is available through Consolidated Dutchwest.

14. Ash overflow in ashbin. If you forget to empty the ashdrawer periodically the ashbin itself will fill with ash. It can be difficult to clean the ash accumulation in the back of the ashbin. We have specifically designed the TS930 and TS940 wrought-iron firesets for this purpose. Included in the set is a hoe which will do the job.

15. Brass dial damper changes color. The brass dials are covered with an anti-tarnish coating, which typically darkens in response to heat. You can use acetone (or nail polish remover, which is mostly acetone) to remove the coating. If neither of these works, try a very fine steel wool, as the coating may come off with this.

16. The cooktop changes color. The cooktop is a solid cast-iron plate that undergoes finishing. It's normal for it to darken in response to heat. Metal polish will keep it clean, but it won't prevent the darkening.

Water formation in the stack. Water vapor is a by-product of wood combustion which condenses at roughly 212 degrees. When the smoke moves slowly up the chimney or during a slow burn when the vapor's temperature out of the stove was already fairly low, the water vapor will lose heat and condense. Dry wood is clearly better in this type of situation than green wood, but even dry wood still gives off some moisture as it burns. If water condensation is still a problem during slow burns with dry wood, you can try to speed up the draft by opening your flue damper more or by introducing more combustion air. This will also serve to keep the chimney warmer. Also, the stove pipe and chimney should be as straight as possible, because turns in the smoke path accelerate the cooling process. Heating up the stack when you start a fire, by running a hot fire for awhile, will help prevent this condition. You can also increase the speed of the draft and dilute the water vapor by opening up the third air source (the one that directs air to the combustor).

Do's and Don'ts of Operating Your Stove

Consolidated Dutchwest sells some of the most sophisticated stoves in the world. These stoves incorporate many features which are unusual in a stove, so it's unlikely you have ever operated a stove like it before. Take the time to read all information provided. It will make for a safer installation, safer operation, and more efficient performance. The following is a brief list of important things to remember.

1. Anyone operating the stove should read the Operating Instructions for a clear understanding of its operation.
2. Your installation should be checked by a local building inspector or, in the event none is available, by a reputable chimney sweep. Most communities require such inspections, **so always contact your local officials for applicable requirements before using your stove.**
3. If installing in a fireplace, the fireplace chimney should be lined and a direct stovepipe connection made between the stove and the chimney liner. Inspect your chimney first for blockage or signs of deterioration and clean or repair if necessary. Do not remove bricks or mortar from the fireplace. An older, unlined chimney, where the masonry was installed against or very close to wood studs or other combustibles can be a very serious fire hazard. If you have any doubts about your chimney, we strongly urge you have it inspected by an expert (building inspector, etc.).
4. **DO NOT CONNECT THIS UNIT TO A CHIMNEY FLUE SERVING ANOTHER APPLIANCE.**
5. Maintain a considerable distance between the stove and any combustible material. Keep the area around the stove clear of furniture, drapery, and other objects. A 48" or greater clearance is recommended. Be sure drapery and loose papers cannot blow closer than this.
6. Never use gasoline, kerosene, oil, lighter fluid or any other liquid fuel in your stove. Such fuels are very dangerous. Approved fuels are untreated wood, bituminous (soft) coal, and anthracite (hard) coal. No other fuels should be used. Cannel coal is not acceptable (its gasses are potentially explosive). Neither are parafin logs. Do not burn garbage in your stove. Failure to follow these guidelines may result in damage to your stove, void the warranty, or even result in a serious chimney or house fire.
7. Your first few fires should be small to medium in size and wood should be your fuel. Cast iron needs a few milder fires to "cure" (reach its maximum strength), so you should not build an intense fire the first few times out. This could crack a casting. Build up each succeeding fire a little hotter. After 4 or 5 fires, your stove will be "cured." See page 15 "Curing Your Stove".
8. When starting a fire or reloading, the by-pass gate must be open. To open, slide a removable door handle onto the bypass damper handle shaft and rotate it clockwise (counterclockwise on model FA264CCL-R, the right-hand loader). If you have a pipe damper or an adapter/damper they must be open as well. If the door(s) are opened while either damper is closed, the stove will smoke heavily. **DO NOT UNDER ANY CIRCUMSTANCES OPEN THE DOOR(S) WHILE THESE DAMPERS ARE CLOSED.** Open the doors a crack for a few seconds before opening all the way. This will help avoid back drafts.
9. **On stoves having both front and side doors, you should never open both doors at the same time.** Otherwise, cross currents could lead to spillage of combustion products from one of the doors.
10. Do not store fuel close to your stove. Four feet or further is a recommended distance. Do not install a stove in a garage which is usually closed. The presence of a stove near combustibles such as gasoline, engine oil, etc. is a very dangerous situation.
11. **DO NOT OPERATE THE STOVE WITH THE ASHDOOR OPEN. THIS WILL LEAD IMMEDIATELY TO EXTREME OVERFIRING.**
12. Do not overfire your stove. A glowing stove or chimney is a sign of overfiring. Immediately close all dampers and monitor the fire until it has returned to a normal level. Do not attempt to overload your stove as this could lead to an overfiring situation. Never run your stove so hot that it glows.
13. Your stove is equipped with a firescreen for open hearth wood burning. Always clip this in place if you want to operate the stove with the front door(s) open. **DO NOT OPERATE YOUR STOVE WITH THE FRONT DOOR(S) OPEN UNLESS THE FIRESCREEN IS FIRMLY IN PLACE. DO NOT BURN COAL WITH THE FRONT DOOR(S) OPEN. BE SURE TO OPEN THE BYPASS DAMPER AND ANY FLUE DAMPER BEFORE PUTTING THE SCREEN IN PLACE. LEAVE THEM OPEN SO LONG AS THE DOOR(S) ARE OPEN.**
14. Your stove is designed to burn natural wood only (with combustor in place). Higher efficiencies and lower emissions generally result when burning dried seasoned hard woods as compared to softwoods or green or freshly cut hardwoods. **DO NOT BURN:** wood that has been treated with anything, including paint, varnish, stain, shellac, etc.; garbage, cardboard, solvents, colored paper (such as catalog stock) or paper printed with colored inks or trash. Burning these may release toxic fumes and may 'poison' the catalytic combustor or make it ineffective. Always remove the combustor when burning coal. Burning cardboard or loose paper can produce soot or large flakes of char or fly ash that can coat the combustor causing smoke spillage into the room and rendering the combustor ineffective. **NEVER BURN PRESSURE-TREATED WOOD** in any stove (with or without a combustor), as it contains a toxic chemical, copper chromium arsenate, a form of arsenic. Burning plywood and chipboard or particle board will also produce toxins.
15. Do not operate the shaker grate(s) with the ashdoor open. Hot coals may fall out. To prevent the spread of dust we further suggest the loading door(s) be closed as well.
16. When using the rotating coal grates **for coal burning**, remember the rotating sections have a range of 90 degrees. For ordinary shaking rotate them 45 degrees. Rotate them 90 degrees only when you wish to dump the coal bed. To rotate more than 45 degrees will probably cause the grate to jam during firing. **If the rotating coal grate(s) jam during on-going operation, wait 45 minutes to an hour. In most cases the trapped coal will be consumed in the fire and you will be able to free up the grate.**
17. When disposing of ash, exercise extreme care. Ash frequently contains hot coals. Dispose of them in a non-combustible container with a tight-fitting lid. Do not dispose of them near a house. Remember, coals may remain hot for a long period of time, so they should never be dumped close to combustible materials. Do not store them in a garage — the possible presence of flammable gasses is a very dangerous situation.
18. Inspect your installation periodically for any evidence of deterioration.

Do's and Don'ts of Operating Your Stove (continued)

19. Each stove comes with removable (slide-off) door handles. They should always be removed when the stove is fired, as they will otherwise become very hot and could cause burns. Small springs are provided to fit inside the handles so they will fall off in case you forget to remove them. A wall-hanging bracket, which can be secured to a wall with two screws, is provided to hold them when the stove is in use. The removable handles can also be used to adjust the dial dampers, open or close the catalytic bypass damper, and remove the firescreen. It is a very good idea to have a pair of insulated gloves, such as the safety gloves (item GL1) available from Consolidated Dutchwest, for use when loading a stove so you won't accidentally burn your hand.

20. Creosote — when wood is burned slowly, it produces tar and other organic vapors which combine with expelled moisture to form creosote. The creosote vapors condense in the relatively cool chimney of a slow-burning fire. As a result, creosote accumulates on the flue lining. When ignited, this creosote can cause an extremely hot and dangerous fire. The chimney connector and chimney should be inspected every two weeks during the heating season. Clean when necessary. To examine the chimney and connector, disconnect the connector from the chimney, and check all inner surfaces. Use a flashlight and mirror if necessary. Take the connector sections outside and remove any deposits with a wire brush. The use of a catalytic combustor will greatly reduce creosote build-up (as much as 90%), but you should still regularly inspect your chimney to be certain it is clean in case the combustor should stop functioning properly. If creosote has accumulated it should be removed to reduce the risk of a chimney fire. Use a chimney brush the same size and shape as your chimney flue. Run the brush up and down the flue; remove fallen creosote from the bottom of the chimney. Our catalogue includes a selection of chimney brushes which will make cleaning easy along with replacement catalytic combustors.

21. Fly Ash — when coal is burned, it produces fly ash, which may accumulate in the chimney, particularly around elbows. You should inspect your chimney every two months (more often if experience dictates) for fly ash if burning coal, and remove it if necessary.

22. Coal Gas — when coal is burned carbon monoxide is produced. Normally, this is drawn up the chimney like the smoke from a wood fire. However, unusual circumstances, such as an obstruction or leak in the chimney, may cause this gas to leak into the house. IT IS EXTREMELY DANGEROUS. While carbon monoxide is odorless, coal fires give off other gasses known as "aldehydes." Aldehydes have a distinctive "sour" odor. Thus a sour odor coming from your stove or chimney during a coal fire means carbon monoxide may be present. The first physical symptoms of carbon monoxide poisoning will normally be a severe headache, dizziness, and possibly an upset stomach. If sour odors or these symptoms are noticed you should (1) immediately open the doors and windows of your house to let in fresh air, (2) shut down the stove by closing the dial dampers all the way, (3) investigate further to determine whether the stove or chimney is leaking, (4) check to see if the chimney has become blocked, (5) if the source of the problem cannot be determined, call in a qualified installer for an inspection, and (6) correct the problem before burning again.

23. Should you ever experience a chimney fire, you should immediately warn everyone in the house. Children, elderly and infirm persons should leave immediately. If the fire is serious or has spread beyond the chimney, everyone should vacate the house immediately and the fire department be called. Only if it is safe to remain, close all the stove's doors and dampers to deprive the fire of oxygen. Do not throw water on the stove as this could cause it to break. It is recommended that you purchase fire extinguishers for your home if you do not already have them. A flare type chimney fire extinguisher can be lit and tossed in the stove. This will create a smoke which consumes oxygen, smothering the fire. Such extinguishers are usually available in local hardware or similar stores and are available through the Consolidated Dutchwest catalogue. We strongly recommend you keep a few on hand. If you have a barometric damper, block the damper door closed so it does not let in more air. If safe to remain, move all furniture away from the stove and chimney (including upstairs if the chimney passes through a second floor). If this does not stop the fire, leave the house and call the fire department. It is also a good idea to hose down the roof to prevent sparks from spreading the fire.



CONSOLIDATED DUTCHWEST

A Division of V.C.I.

P.O. Box 501, Bethel, Vermont 05032

1-800-22-STOVE (1-800-227-8683)